

**THIS TECHNICAL MANUAL HAS BEEN DEVELOPED FOR AND
INTENDED TO BE USED BY A QUALIFIED TECHNICIAN
WORKING FOR AN AUTHORIZED KI MOBILITY DEALER.**

ROGUE 2

TECHNICAL MANUAL



WARNING

WARNING: Repairs and adjustments not made by a qualified technician working for an authorized Ki Mobility Dealer can result in poor performance or failure of the device which may cause serious injury or death.

This technical manual is designed to aid in the different procedures that may be needed for the Rogue 2 wheelchair. This technical manual does not replace, but aids the user instruction manual, adjustment guides and instructions. The procedures shown in this technical manual should only be performed by an Assistive Technology Practitioner (ATP) or clinical professional trained to do wheelchair repairs, adjustments and retrofits.

Additional information can be found in the Rogue 2 User Instruction Manual. The user instruction manual can be found on the Ki Mobility website.

If you have any questions or concerns about any aspect of this wheelchair, this manual, or the service provided by us or your retail supplier, please do not hesitate to contact us by telephone at:

715-254-0991

In writing at:

Ki Mobility
5201 Woodward Drive
Stevens Point, WI 54481
U.S.A

Via email at:

sales@kimobility.com

Or via our Authorized EU Representative:

Etac Supply Center AB
Långatan 12
33233 Anderstorp
Sweden

Table of Contents

Tools.....	3
Frame Tube Size Guide.....	3
Chair Measurement References.....	4
Caster Mount	5
Caster Forks and Stems	6
Caster Angle and Squaring	12
Index Towers and Camber Tube.....	13
Backrest Assembly	16
Height Adjustable Back Post	19
Fixed Height Back Post	20
Height Adjustable T-Arm.....	21
Swing Away Armrest.....	22
Cane and Crutch Holder	23
Luggage Carrier	24
Handrim Configurations	25
Handrim Construction.....	26
Seat Pan.....	27
Seat Upholstery.....	28
Side Guards	29
Transit	33
Hybrid Angle Adjustable Footrest	34
Angle Adjustable Footrest.....	35
Angle Adjustable Flip Under Footrest	36
High Mount Angle Adjustable Footrest	37
High Mount Angle Adjustable Flip Under Footrest	38
Adjusting the Footrest.....	39
Anti-Tips.....	40
Wheel Locks.....	41
Reversing Wheel Lock	43
Center of Gravity Adjustment.....	46
Seat Height Adjustment	47
Setting Toe to Zero	48
Wheelbase Width Adjustment.....	49
One Arm Drive (OAD)	50

Tools

Please see the list below to identify the tools needed throughout this tech manual. Always check tools to ensure the ends are not stripped and that the tool can perform its function properly without damaging any parts or hardware on the chair.

Tools Needed	
• 2.5mm Allen Wrench	• Two 8mm Wrenches
• 3mm Allen Wrench	• Two 10mm Wrenches
• 4mm Allen Wrench	• 13mm Wrench
• 5mm Allen Wrench	• 17mm Wrench
• 5.5mm Allen Wrench	• 19mm Wrench
• 6mm Allen Wrench	• 24mm Wrench
• Utility Blade	• Phillips Screwdriver
• Torque Wrench	• Punch (or small screwdriver)
• Rubber Mallet	

Frame Tube Size Guide

Tubing sizes subject to change without notice

This information is a reference for situations where the tube sizes are needed for certain attachments.

Rogue 2
Frame Tube
Frame Tube: 1 3/8"
Camber Tube: 1 1/8"
Back Canes
Fixed Height Back Canes: 1"
Rigidizer Bar: 7/8"
Lower Height Adjustable Back Tube: 1"
Upper Adjustable Upper Back Tube: 3/4"
Half Folding Back: 7/8"
Arms
Swing Away: 1"
Upper T-Arm: 7/8"
Transfer Tube T-Arm: 3/4"
Angle Adjustable Flip Up: 1"
Footrests
Footrest Tubes: 3/4"

Chair Measurement References

The Rogue 2 wheelchair is capable of many adjustments to configure the chair to the user's needs. See the diagram below for terms that are commonly used during the process of adjusting the chairs.

A. Seat Width See Diagram 1

Measured from outside of frame tube on one side to outside of frame tube on other side.

B. Seat Depth See Diagram 3

Measured from front of back posts to front edge of seat sling. Seat sling starts at beginning of bend at front of frame.

C. Sling Position See Diagram 2

In Performance Position (0°), sling is at front of frame to keep chair shorter and more maneuverable. The 1" or 2" seat sling position extends the frame in front of the sling by that amount. Adding more frame can improve stability and provide support to aid in transfers.

D. Front Frame Bend See Diagram 3

Angle between front seat tube and ground.

E. Footrest Taper See Diagram 1

Indicates bend of front frame creating footrest. Taper is measured from outside of seat frame to outside of front tube.

F. Front Seat Height See Diagram 1

Measured from floor to top of seat tube at front of seat sling.

G. Footrest Width See Diagram 1

Measured from inside of front tube to inside of front tube on other side. Footrest width is listed below for each seat width and taper.

Seat Width	Straight	1" Y Taper	2" Y Taper	3.5" V Taper	7" V Taper
Outside Measurement	2" Narrower than Seat Width	4" Narrower than Seat Width	6" Narrower than Seat Width	4" Narrower than Seat Width	6" Narrower than Seat Width
12"	9.5"	7.5"		7.5"	
13"	10.5"	8.5"		8.5"	
14"	11.5"	9.5"		9.5"	
15"	12.5"	10.5"		10.5"	
16"	13.5"	11.5"	9.5"	11.5"	9.5"
17"	14.5"	12.5"	10.5"	12.5"	10.5"
18"	15.5"	13.5"	11.5"	13.5"	11.5"
19"	16.5"	14.5"	12.5"	14.5"	12.5"
20"	17.5"	15.5"	13.5"	15.5"	13.5"

H. Seat to Footrest Length See Diagram 3

Measured from front edge of seat sling to top rear of footrest. Footrest length of at least 2.5" shorter than front seat height recommended.

I. Rear Seat Height See Diagram 3

Measured from floor to top of seat tube at front of back post. Rear seat height is custom to needs.

J. Center of Gravity Preset See Diagram 3

Measured from front of back post to center of rear axle. 0" indicates axle will be directly under back post.

K. Rear Wheel Spacing See Diagram 1

Measured from outside of seat back to inside of rear tire. Adjustable out .5" from setting.

L. Caster Position See Diagram 4

The Optimized Position keeps the casters tighter to the frame for enhanced maneuverability. Expanded Position pushes the casters out .75" past the Optimized Position for increased stability.

Diagram 1

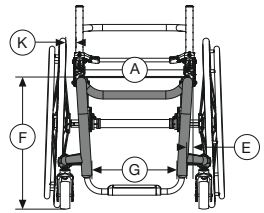

Diagram 2

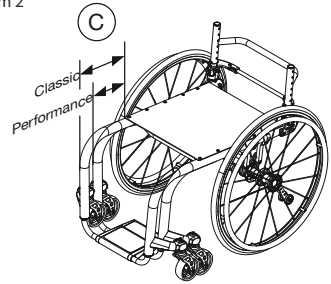

Diagram 3

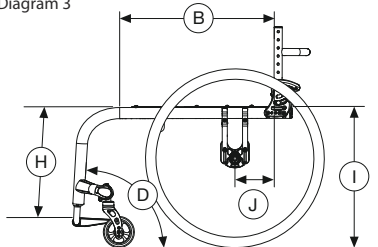
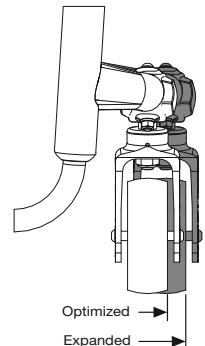
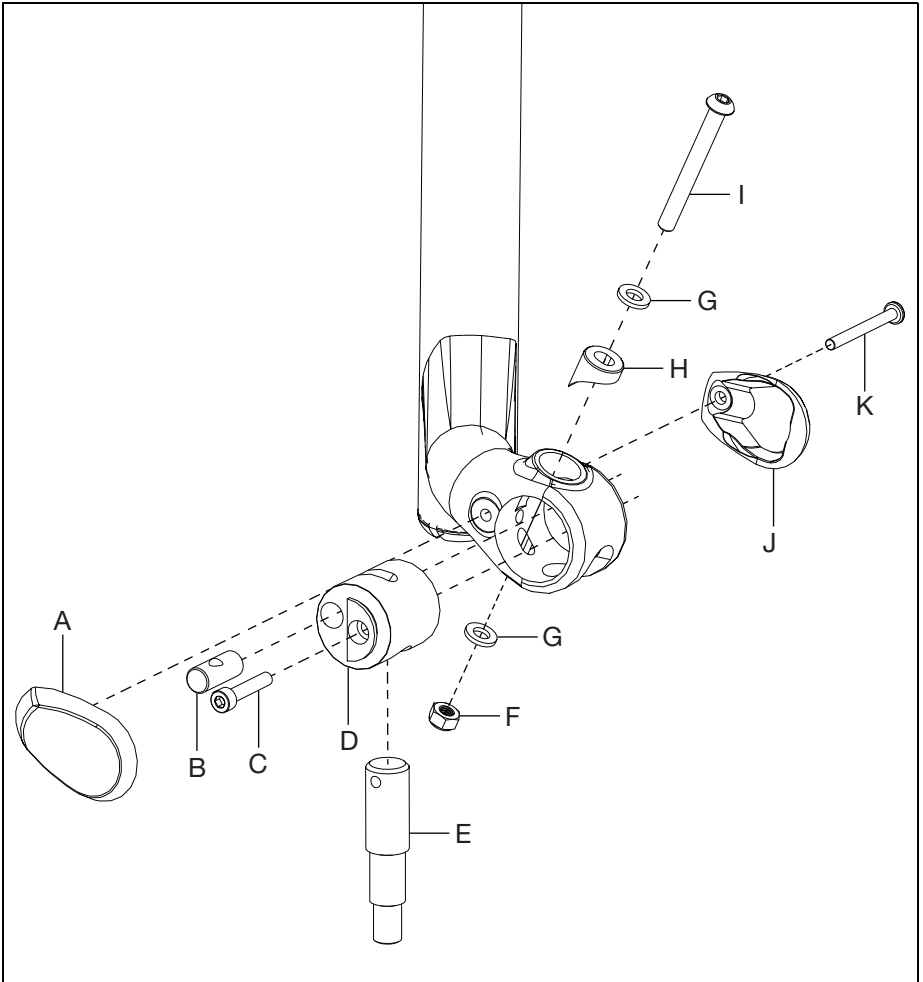

Diagram 4



Caster Mount

1. Install the caster lock barrel (D) into the caster housing.
2. Install the caster stem (E) in through the bottom of the caster housing and into the caster lock barrel (D). Secure in place by installing the M5 bolt (C) through the caster lock barrel (D) and into the stem (E) using a 4mm Allen wrench.
3. Install the caster lock threaded barrel (B) into the caster lock barrel (D) with hole facing upward.
4. Install the M6 bolt (I) through the washer (G), caster lock saddle (H), caster housing opening, caster lock barrel (D), caster lock threaded barrel (B) and second washer (G). Secure with nut (F) using a 4mm Allen wrench and a 10mm wrench.
5. Close the caster housing assembly by installing the caster wing covers (A & J) with the M4 bolt (K) using a 2.5mm Allen wrench.



Caster Forks and Stems

Remove Caster Fork and Stem

1. Remove bottom nut and washer using a 17mm or 3/4" socket wrench. Remove fork assembly.

NOTE: Based on your configuration, the caster may need to be removed first to allow clearance for wrench (See step 3).

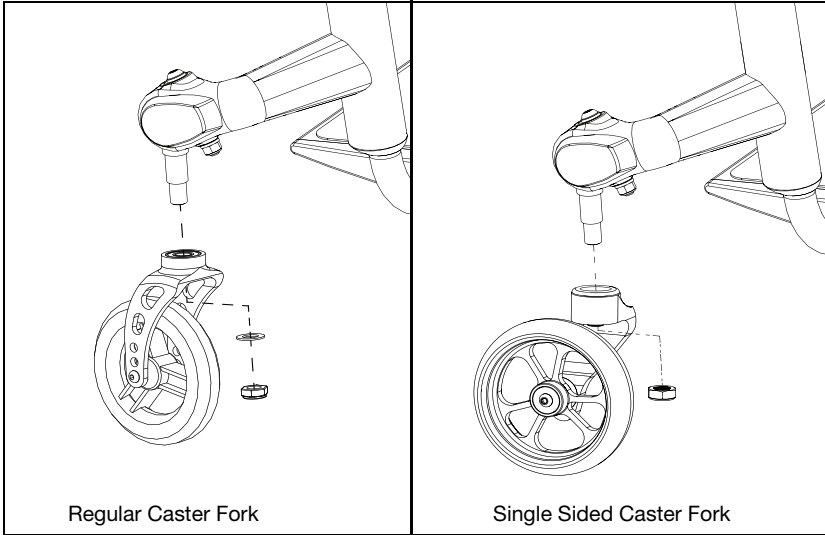

2. Remove the caster wing covers by removing the M4 bolt with a 2.5mm Allen wrench. Remove the caster stem by removing the M5 bolt with a 4mm Allen wrench.

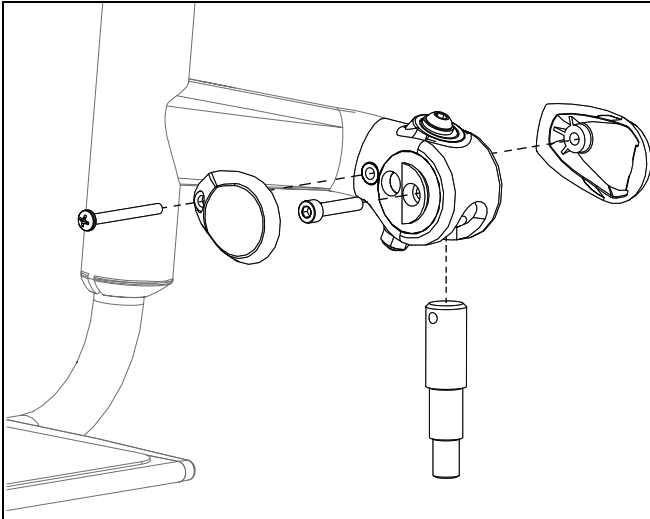

Caster Forks and Stems

3. If you are replacing your forks continue for instructions. For a regular caster fork, remove caster wheel by removing two socket head screws and two spacers using two 4mm Allen wrenches. For a single sided fork, remove the socket head screw, axle shaft and E-Clip using a 5mm Allen wrench.

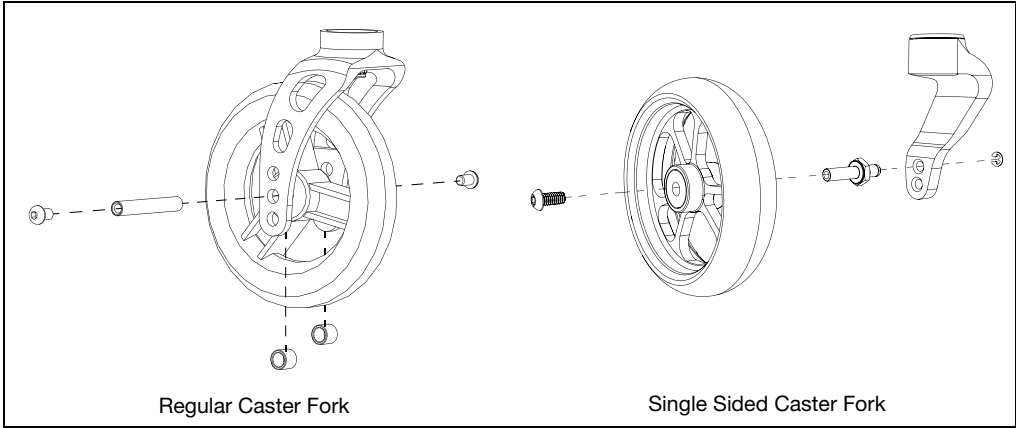

Install Caster Fork and Stem

1. Install stem (A) into fork (B) with washer (E) and nut (F) using a 16mm wrench.
2. Install caster wheel (H) into fork (B) with two screws (C), a threaded barrel (D) and two spacers (G) using two 4mm Allen wrenches.

NOTE: There is one size of caster stem (standard) and three sizes of forks (tall, standard and short) that can be used. The image below shows the stem and forks. The installation process is the same for whichever stem and fork you use.

3. Install assembly to caster housing by installing the two socket screws seen in step 2 on previous page.

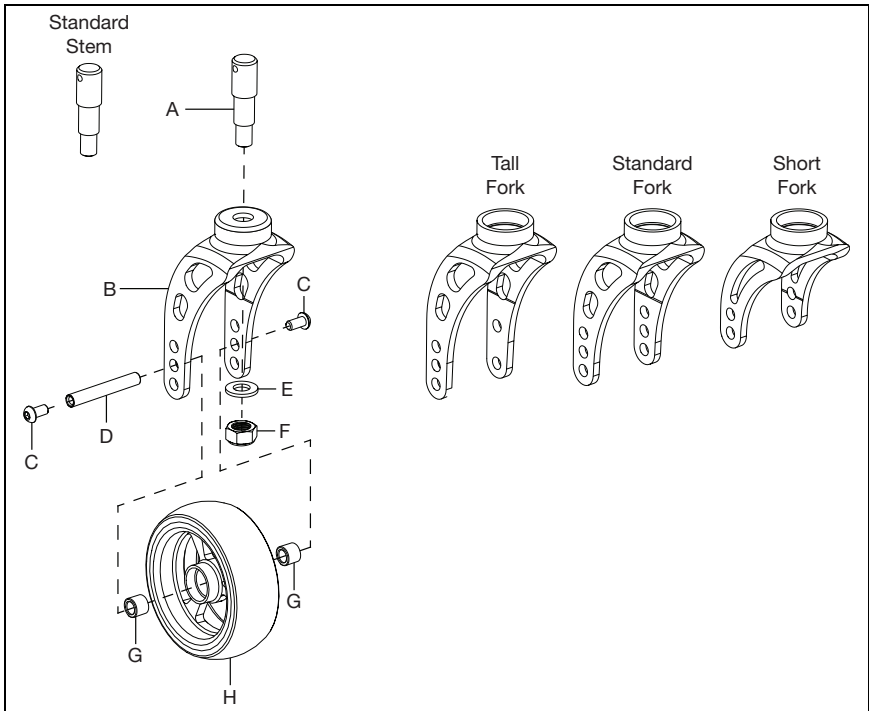

Caster Forks and Stems

Single Sided Fork

1. Install stem (A) into single sided fork (B) with washer (C) and nut (D) using a ½" wrench.
2. Install caster wheel (F) onto fork (B) with a screw (E), the axle shaft (G) and secure with E-Ring (H).

NOTE: There are two sizes of caster stems (standard and +3/4") and two sizes of forks (short and tall) that can be used. The installation process is the same for whichever stem and fork you use.

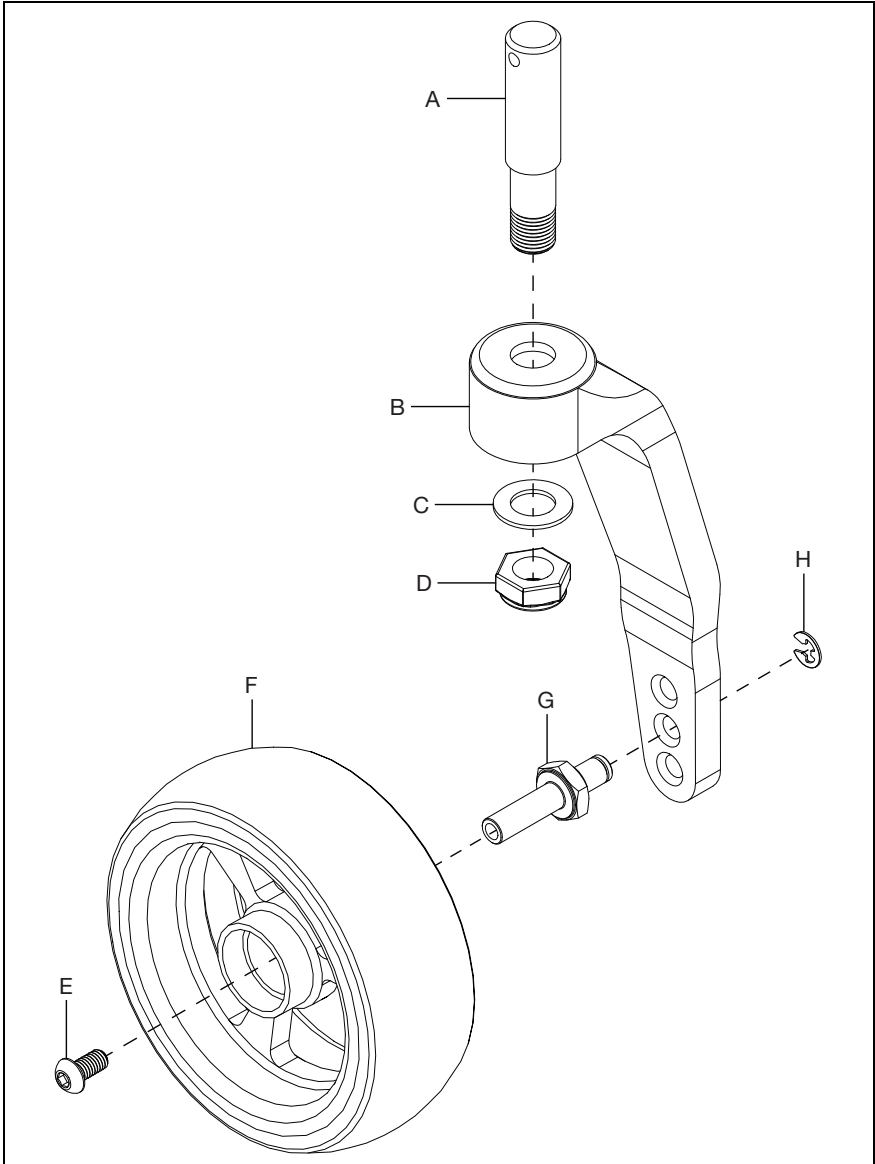

Caster Forks and Stems

Frog Legs Ultra Sport Fork Assembly

1. Install Frog Leg Ultra Sport Fork (A) onto caster wheel (E) with axle (B), screw (C) and two spacers (D) using two 4mm Allen wrenches.

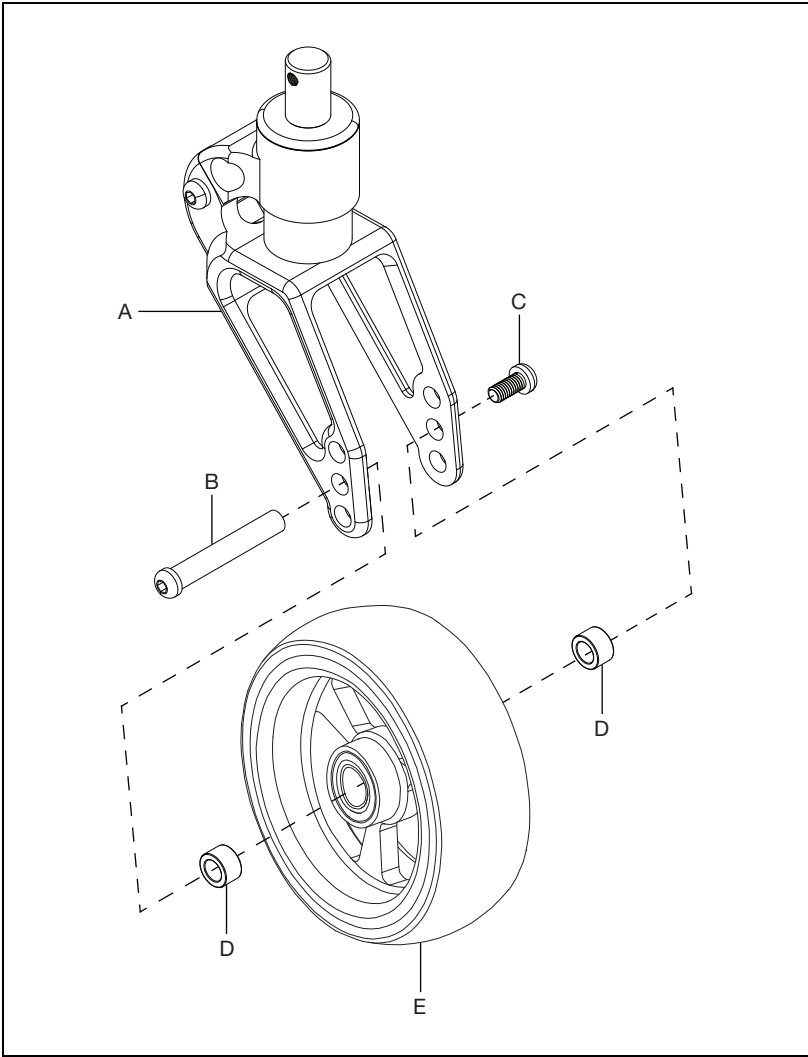

Caster Forks and Stems

Frog Legs Phase 2 Carbon Fork Assembly

1. Install Frog Leg Phase 2 Carbon Fork (A) onto caster wheel (E) with axle (B), screw (C) and two spacers (D) using two 4mm Allen wrenches.

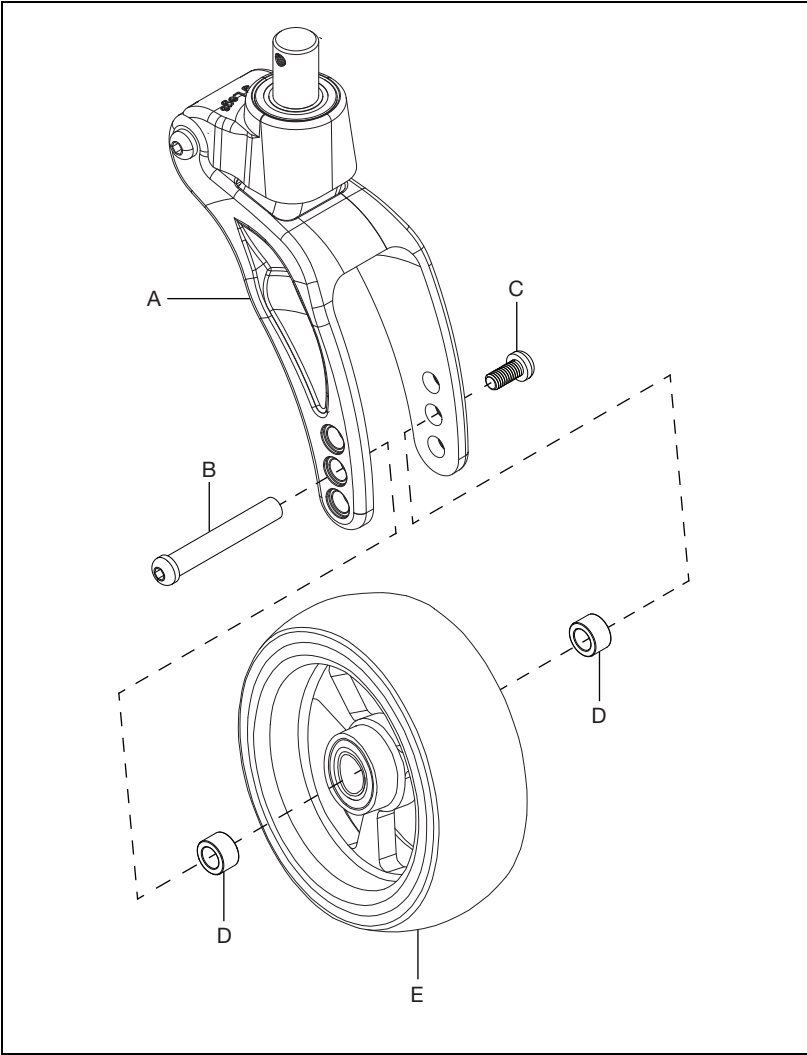

Caster Forks and Stems

Frog Legs Ultra Sport Fork Polymer Replacement

NOTE: The Ultra Sport fork has different polymers that can be used based on the chair user's weight and preferred ride. The Phase 2 fork has one polymer that works for any configuration. If ever needed, the replacement procedure is the same for a Phase 2, but no coin is needed.

1. Remove the pivot pin screw (D) using a 4mm Allen wrench.
2. Use a punch or small screwdriver and a rubber mallet to push the pivot pin (A) out.
3. Open the fork assembly and remove the polymer (C) and coin (B).
4. Install the new polymer (C) and coin (B).
5. Insert the pivot pin (A) back into the fork assembly. A punch or small screwdriver can be used to help align holes if needed.
6. Secure the assembly by reinstalling the pivot pin screw (D) using a 4mm Allen wrench.
7. Repeat steps on opposite side.

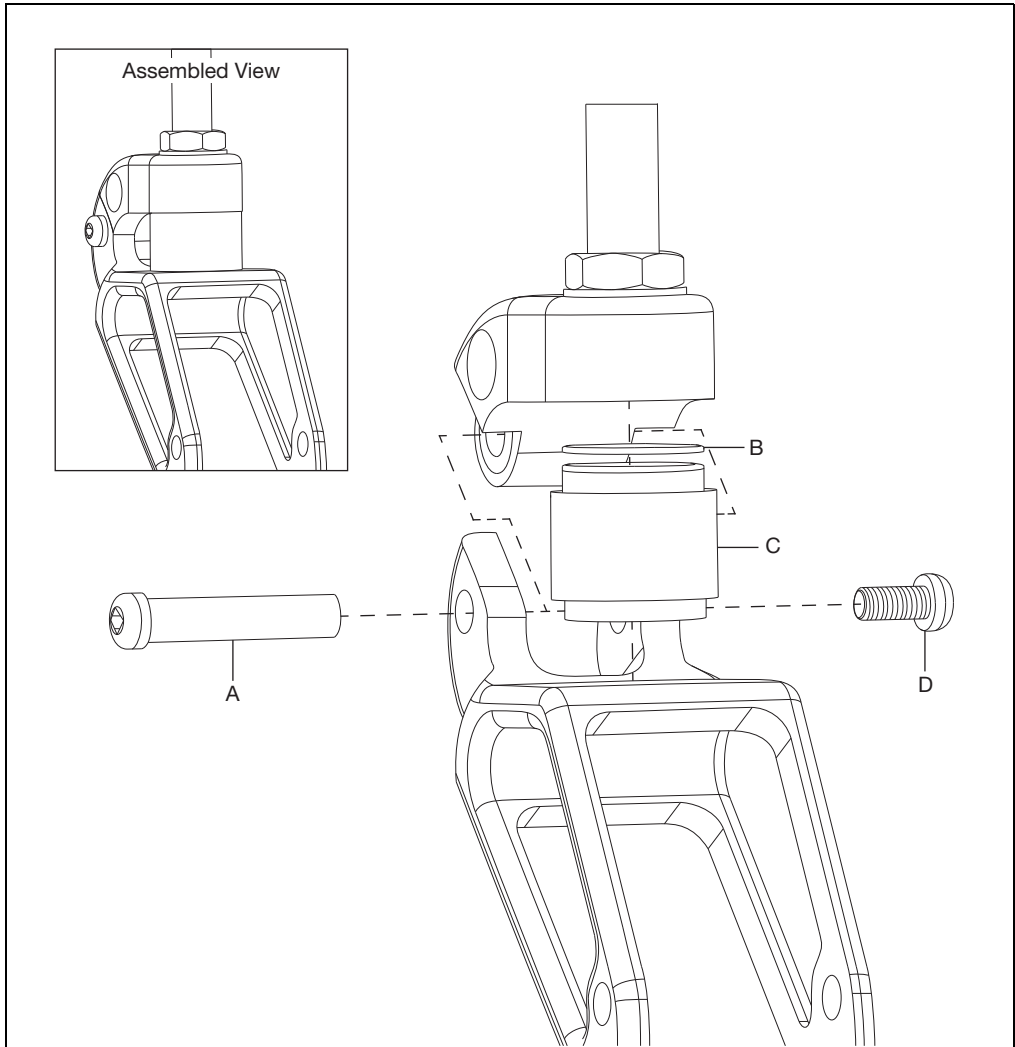

Caster Angle and Squaring

To maintain optimal performance of your Rogue 2, the front caster housing should always be aligned perpendicular to the ground. Your Rogue 2 is shipped aligned. It is recommended that caster squareness is checked after making adjustments to the chair configuration related to any of the following items: caster size or type, camber, rear wheel, tire, center of gravity and seat heights. Caster squareness should always be the last check made prior to use after adjustments or changes to the chair have been made.

After all other adjustments are made you should check your caster housing alignment and realign if the housing is not perpendicular to the ground.

Caster flutter is another issue relating to caster angle and squaring. This is often caused by high speeds, misalignment of caster to ground and looseness in the caster/fork/stem assembly. To address caster flutter, first ensure all fasteners in the caster, fork and stem assembly have been appropriately tightened down and there is no excessive play between any of the parts. If the issue remains, ensure the caster is square by adjusting the caster angle as demonstrated below. Lastly, if the flutter still remains, open the caster angle. You can open the caster angle 1° at a time, up to 2° forward or 2° rearward. This is done in the same manner as squaring the caster but changing the angle 1° at a time, testing the flutter then adjusting again if needed. An angle finder is helpful when changing 1° at a time.

Adjusting the Caster Angle:

1. Loosen the lower nut (B) a quarter turn using a 10mm wrench.
2. Turn the button head cap screw (A) with a 4mm Allen wrench.
3. The caster assembly will move toward the front of the chair when adjusted clockwise and away from the chair when adjusted counter-clockwise.
4. Set the bubble level clip on the fork and set the caster perpendicular to the ground.
5. Tighten the lower nut (B) to 50 in/lbs when all adjustments are set and final.

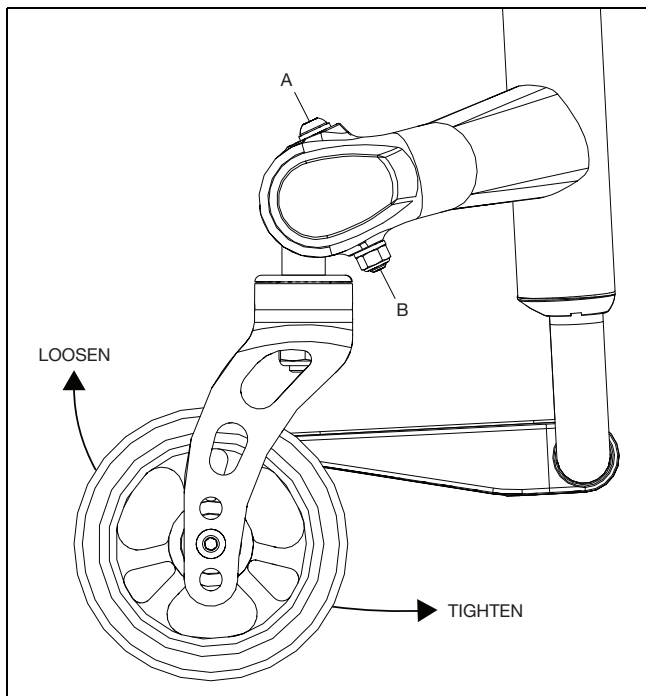

Index Towers and Camber Tube

NOTE: The install is easier if the frame is flipped upside down as shown below.

1. Install the dimple buttons (B) into the rear index clamps (A & C).
2. Install the rear index clamps (A & C) onto the frame along with the rear tower outer clamps (D) with two bolts (F) and two washers (E) per side, using a 5mm Allen wrench.
3. Repeat on the opposite side, ensuring both sets of index clamp assemblies are set in the same location on both sides of the frame.

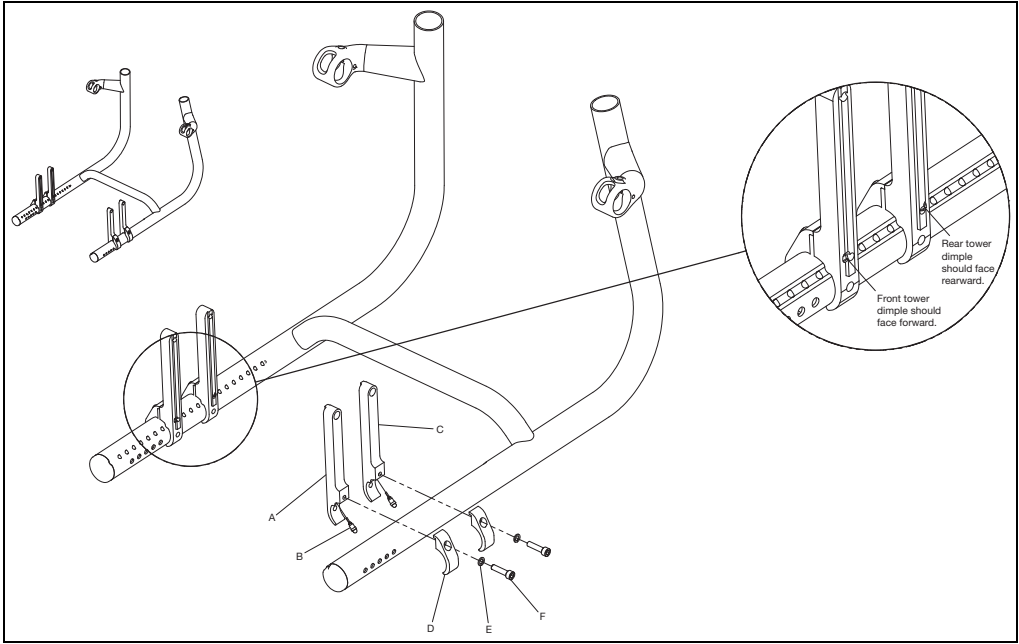

4. Install the upper base mount (B) onto the rear index clamps with two bolts (D), two washers (C) and two square nuts (A) per side using a 5mm Allen wrench. Repeat on opposite side.

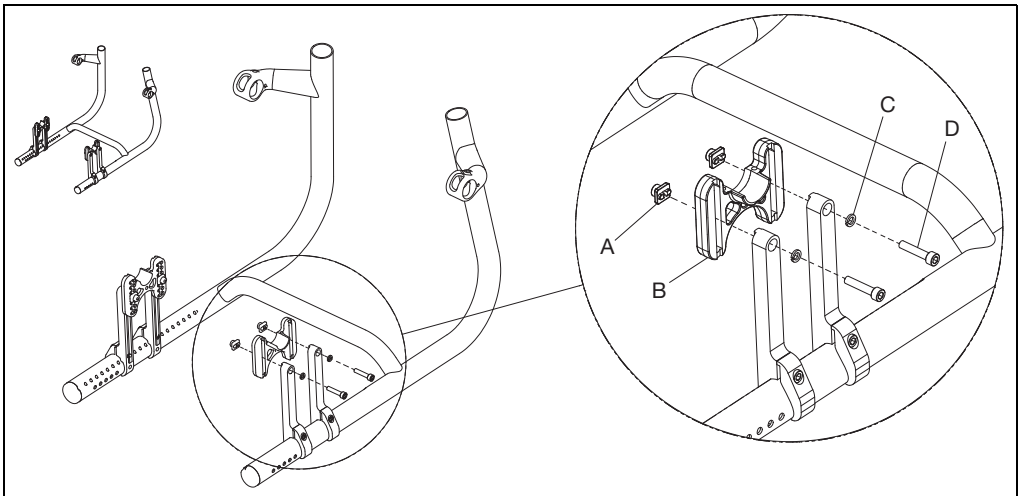

Index Towers and Camber Tube

- When standard anti-tips are present - Install the anti-tip mount (D) onto the upper base mount with bolt (C) and nut (E) using a 4mm Allen wrench and a 2.5mm wrench. Do not fully tighten until full camber tube assembly is complete.
- Install the anti-tip assembly (A) into the anti-tip sleeve (B). Install the anti-tip assembly and sleeve into the anti-tip mount and ensure index button "clicks" and locks into one of the holes in the anti-tip mount.
- Install the camber tube (F) into the opening in the anti-tip mount.

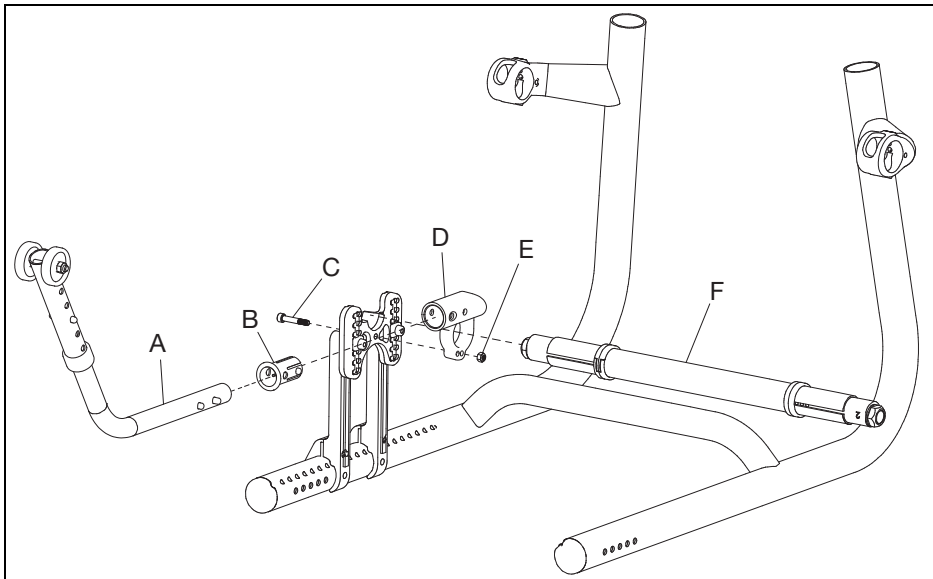

- When user activated anti-tips are present - Install the anti-tip spacer (C) and anti-tip assembly (B) onto the upper base mount with bolt (A) and nut (D) using a 4mm Allen wrench and a 2.5mm wrench. Do not fully tighten until full camber tube assembly is complete.
- Install the camber tube (E) into the opening in the anti-tip mount.

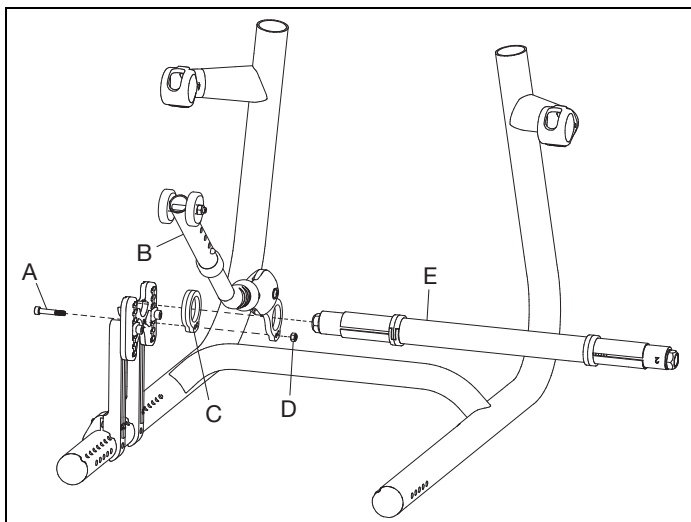

Index Towers and Camber Tube

1. For standard camber tube installation (no anti-tip present) - with the camber tube (C) in place, secure with lower base mounts (B) and two bolts (A) per side using a 4mm Allen wrench.
2. Tighten the four bolts to 50 in/lbs in the sequence shown below (1,2,3,4).
3. Slide the tower index clamp assembly along the dimple track to the the desired CG position. CG is measured from the front of the back cane to the center of the camber tube axle receiver.
4. Tighten all tower clamp bolts (D) to 70 in/lbs to secure in the desired position.

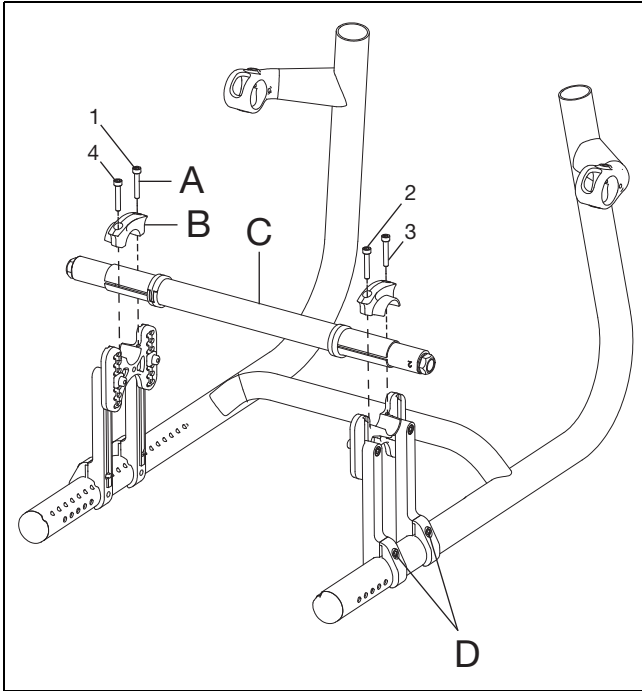

Backrest Assembly

Backrest Installation

NOTE: Remove existing backrest before beginning the installation process.

NOTE: If replacing the whole backrest, the backrest will come as an assembly and the first two steps can be skipped.

1. Install the release lever assembly (B) onto the back post (A) with a screw (D) and nut (C) using a 3mm Allen wrench. The screw will pass through the tube sleeve (E) and release pin (G) which are installed up through the bottom of the back post. The compression spring (F) is installed up through the bottom of the back post also, but the bolt doesn't pass through it. Repeat steps on opposite side of back post.

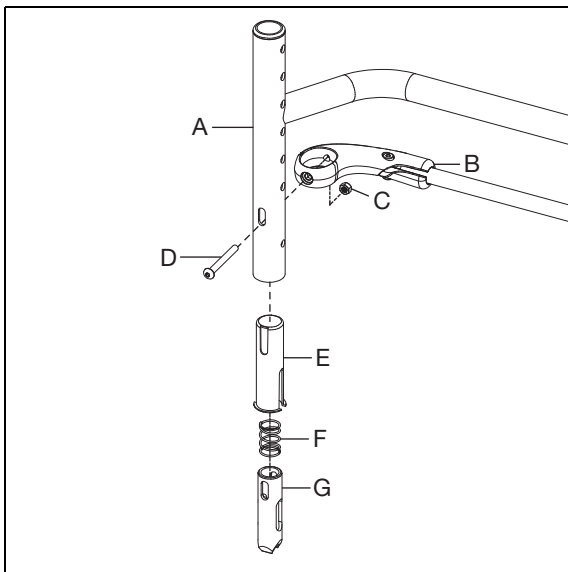

2. Secure the relax bumper (C) to the relax saddle (B) with the screw (A) using a 4mm Allen wrench. There are three index slots that the screw can be installed in - the top (9°), middle (4°) and bottom (0°). Install the screw in the desired position and repeat steps on the second set of saddles and bumpers. Ensure both sides are set in the same position.

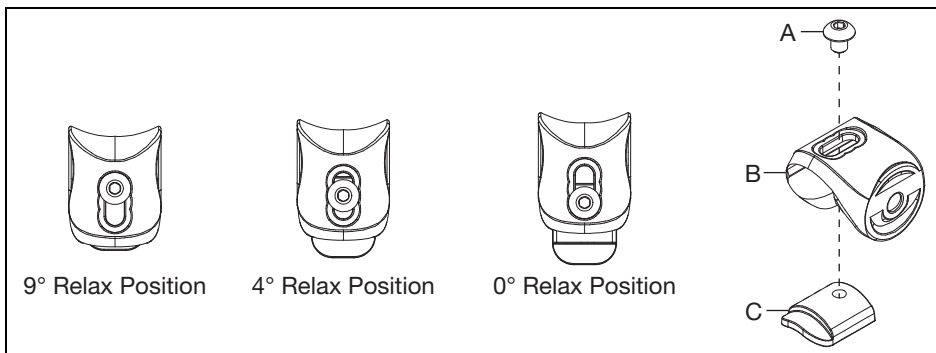

Backrest Assembly

3. Secure the new backrest plate (E) to the backrest post with the barrel nut (A) and 3/8" external retaining ring (J) using a pliers.
4. Secure the top of the backrest plate (E) to the backrest post with the shoulder bolt (C), fender washer (K) and nut (L) using a 3mm Allen wrench and an 8mm wrench.
5. Install the adjustment screw plug cap (B) through the backrest plate. Install the bolt (F) in through adjustment screw plug cap (B) and secure by installing the plug cap adjustment screw (H) over the top and the 5/8" retaining ring (I) over the top of both plug cap pieces. See the zoomed in image below for details of this procedure.
6. Install the bolt (D) through the backrest plate into the strike (G).
7. Repeat steps on opposite side of the backpost.

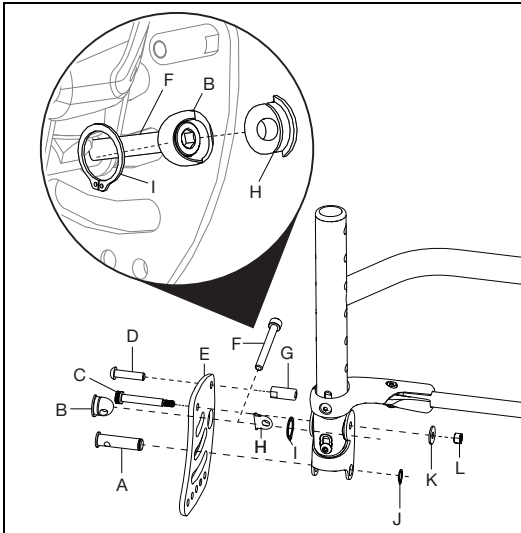

8. Install the backrest assembly onto the chair with the hardware shown below. A 10mm wrench and a 4mm Allen wrench are needed.

NOTE: The holes that the backrest assembly is installed with on the seat frame depend on the desired seat depth desired. Set as needed for desired configuration.

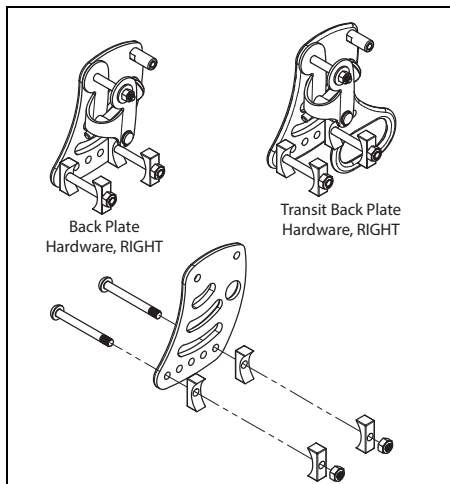

Backrest Assembly

Adjusting Backrest Angle

1. The backrest angle can be adjusted by using a 5mm Hex drive, as shown below. Turning the hex drive clockwise decreases the backrest angle and turning it counterclockwise increases the angle. Each angle indicator mark on the back plate is 3° and 3° of angle change takes roughly 2.5 turns.

NOTE: Ensure both sides of the backrest are set in the same position. Use the angle indicator marks as a guide.

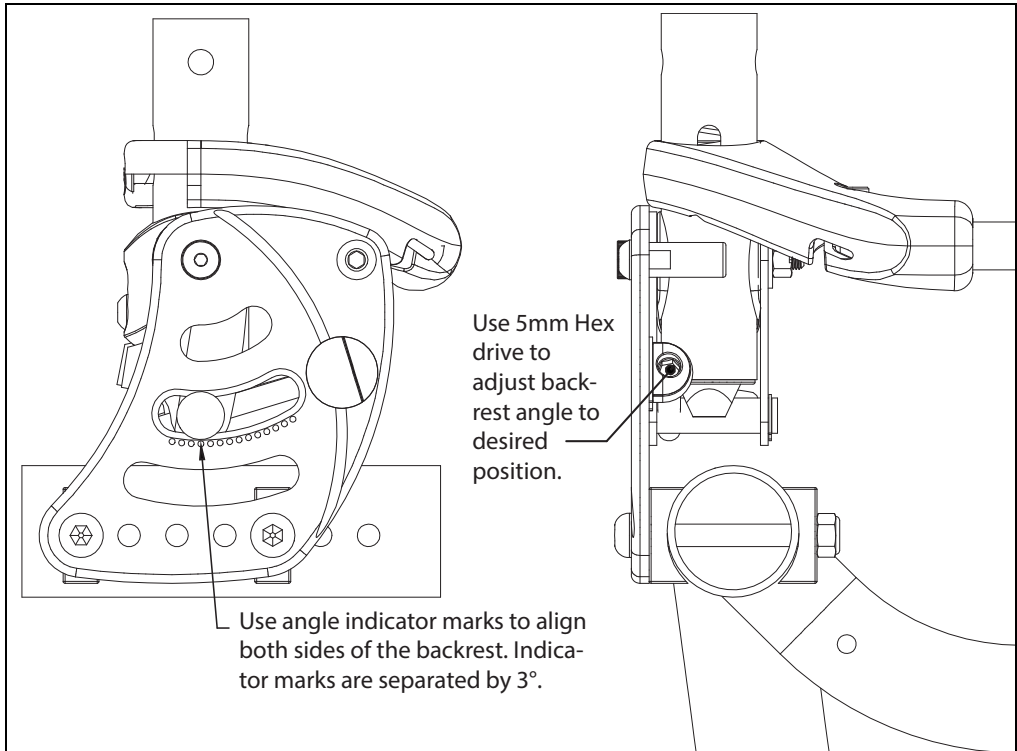

Height Adjustable Back Post

1. Install the height adjustable back post (F), plugs (G), sleeve (E), screws (C), threaded barrels (D) and the upper back tube assembly (A) using two 3mm Allen wrenches.

NOTE: The straight upper back, standard push handle and fold down push handle upper backs are shown in the image below.

NOTE: The hole patterns on the lower section of the tubes differ between designs, but the process of installation and adjustment is the same.

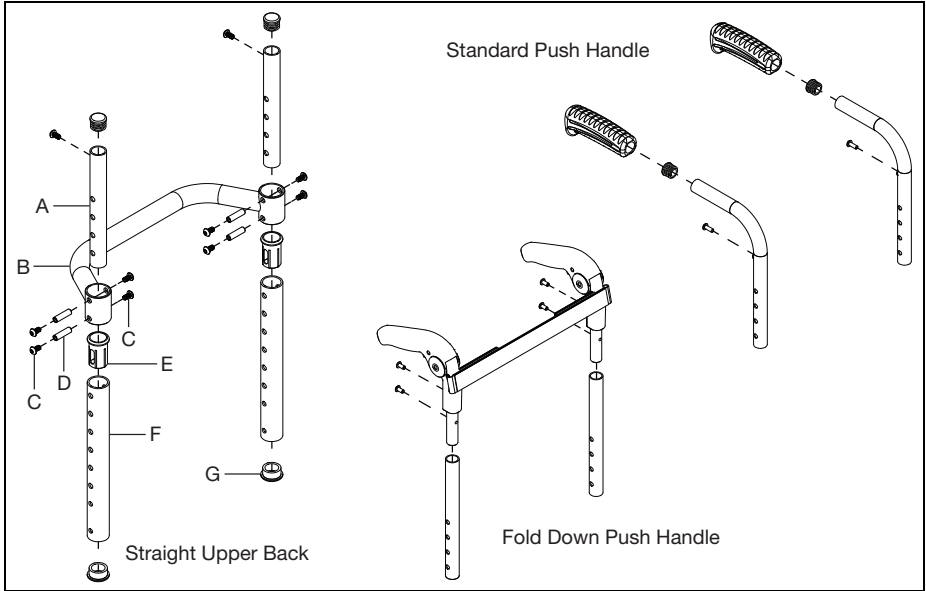

Fixed Height Back Post

1. For the fixed height back post, install the rigidizer bar (D), screws (A & C), threaded barrels (B) and plugs (E) using two 3mm Allen wrenches.

NOTE: The fixed height back post, standard push handle and fold down push handle upper backs are shown in the image below. The standard push handle and fold down push handle upper backs also require sleeves, upper post assemblies and the handle hardware. See image below for details.

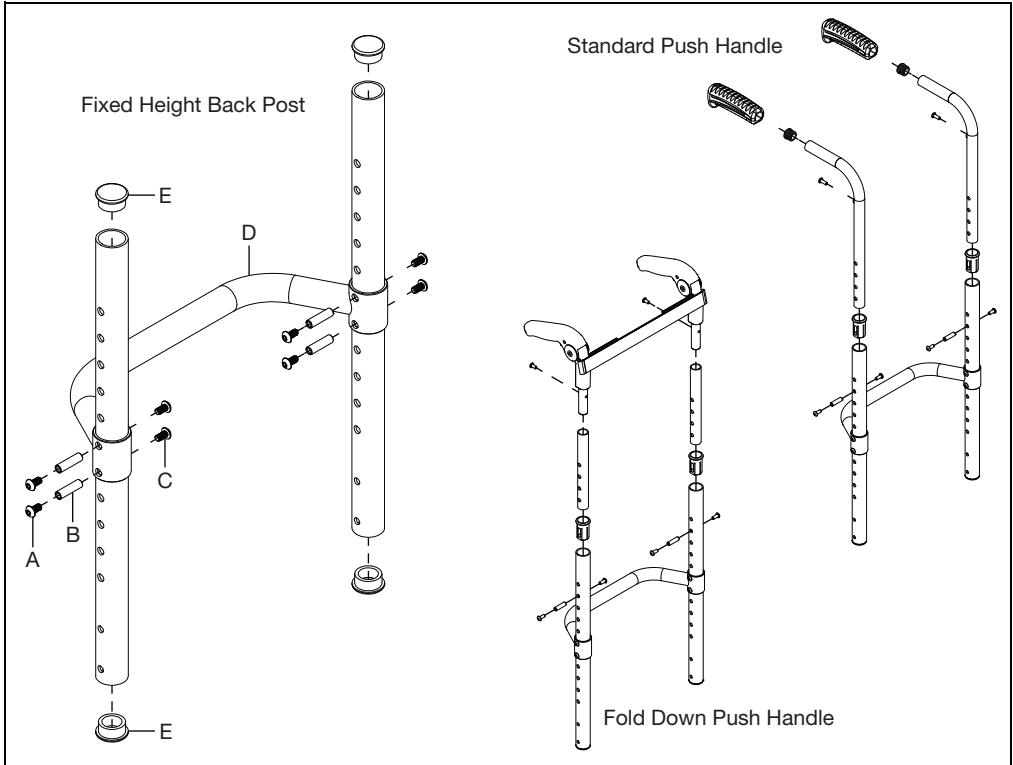

Height Adjustable T-Arm

1. Install the T-Arm receiver (B) and the T-Arm bracket (C) onto frame with two bolts (D) and two nuts (A) using a 5mm Allen wrench and a 10mm wrench.

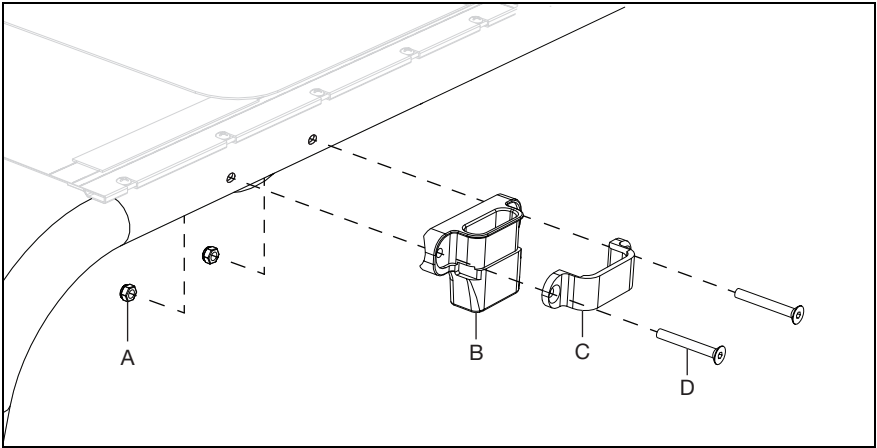

2. Install the T-Arm assembly into the receiver. Ensure the latch (B) "clicks" into place. Adjust the height by loosening the height lever (A) and sliding the T-Arm post up or down. Repeat steps on opposite side.

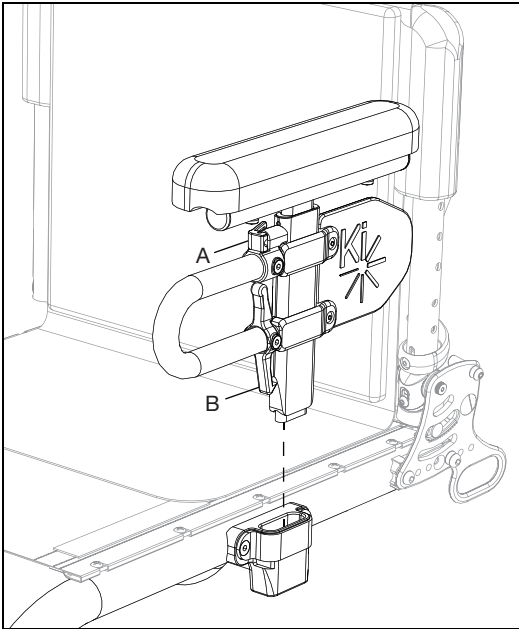

Swing Away Armrest

1. Install the tube plug (B) into the swing away arm (C) (if not already assembled).
2. Install the armrest foam (A) over the swing away arm (C) (if not already assembled).
3. Set the height of the swing away arm by using one of the three possible holes and install the two bolts (D) using two 5mm Allen wrenches.

NOTE: The highest hole on the swing away arm will provide the lowest setting. The lowest hole will provide the highest setting.

4. Install the swing away arm assembly into the receiver (G) with the sleeve (F).

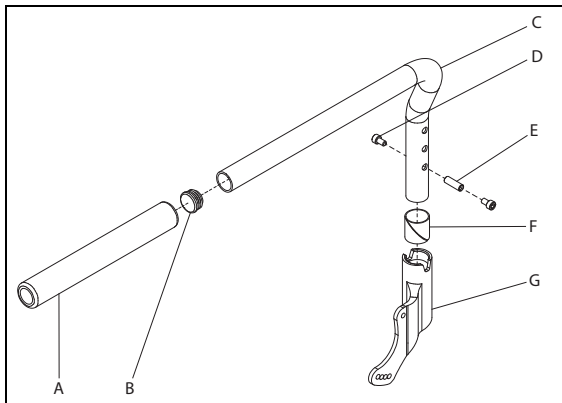

5. Install the swing away arm assembly onto the outside of the backplates with three bolts (D,E & F), four saddles (B - 2 inside of frame, 2 outside of frame), two nuts (A) and a strike (C). A 4mm Allen wrench and a 10mm wrench are needed for the install. If existing hardware is present on the backplate, remove and install what is shown below.

NOTE: Install the bolt (E) into the angle hole on the swing away receiver that makes the swing away armrest parallel with the ground.

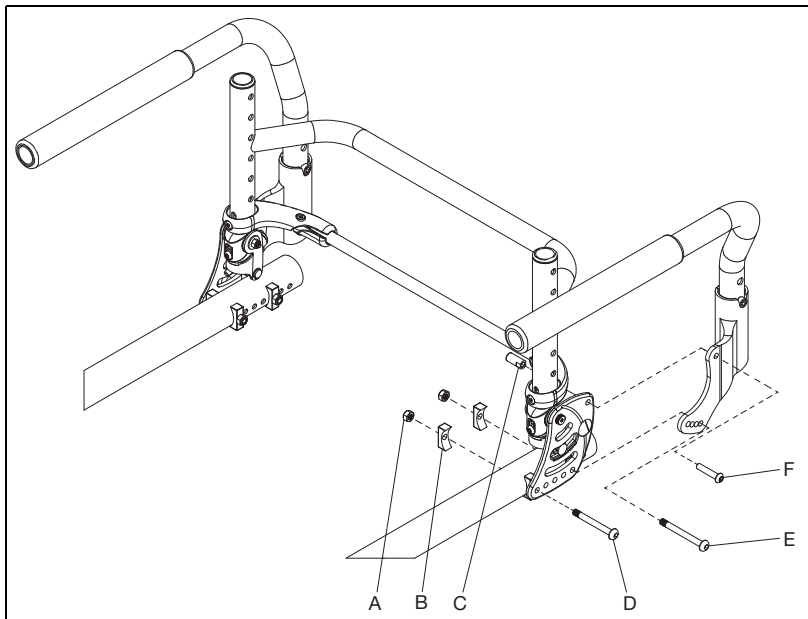

Cane and Crutch Holder

1. Install crutch holder cup (I) onto the crutch holder tube (F) with two screws (J), two washers (H) and two nuts (G) using a 3mm Allen wrench and an 8mm wrench.
2. Install the crutch holder tube assembly onto the camber tube with the clamps (D & E) and two bolts (C) using a 5mm Allen wrench.
3. Install the crutch holder velcro strap (A) onto the back post (ensure the crutch holder cup and velcro strap are on the same side of chair) with a screw (B) using a 3mm Allen wrench.

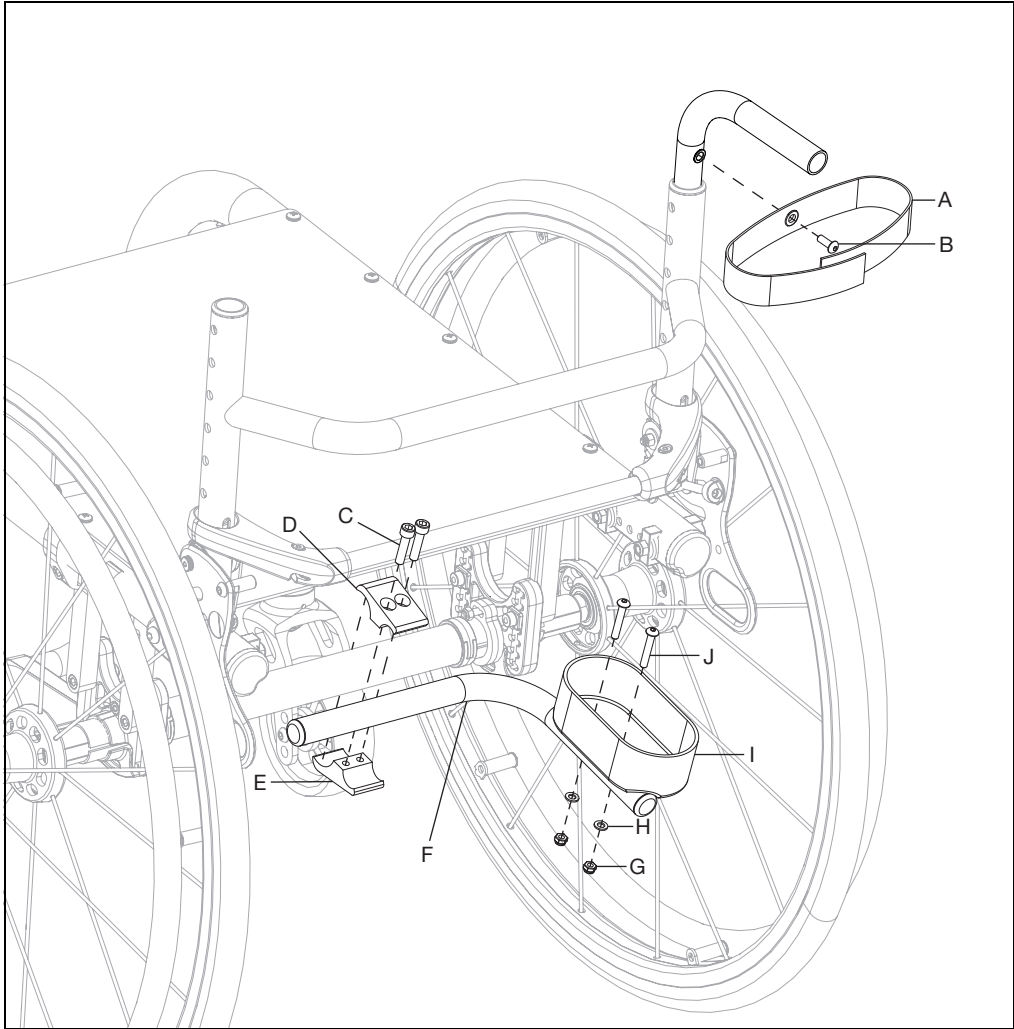

Luggage Carrier

NOTE: There are different sizes of clamps to fit all types of chairs and configurations. The carrier can be mounted to the frame or footrest tube on Rigid chairs. The installation is the same whether it is installed on the frame or footrest tubes.

1. Install luggage carrier fork (B) and clamp (E) by installing two screws (A) and barrel nut (C) through the clamp and fork using two 4mm Allen wrenches.
2. Secure the clamp in the desired location by installing and tightening the screw (F) and nut (D) on the backside of the clamp using a 5mm Allen wrench.

NOTE: The nut for the backside screw goes into a recess in the clamp. Ensure that nut stays in place.

3. Repeat on opposite side.

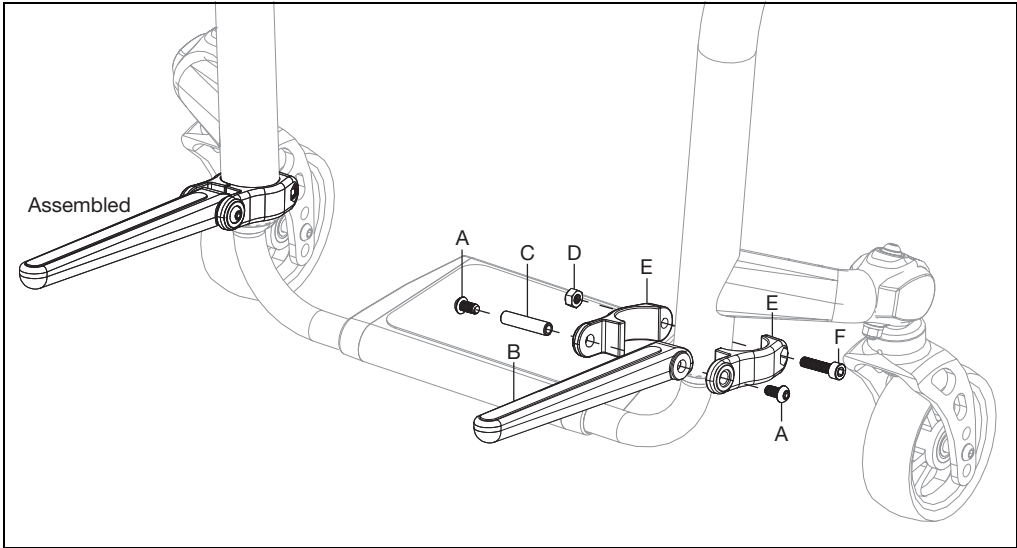

Using the Luggage Carrier

1. Operating position for the luggage carrier is when the forks are folded down (See image below). The max weight capacity is 55lbs.
2. When not in use, fold the luggage carrier up.

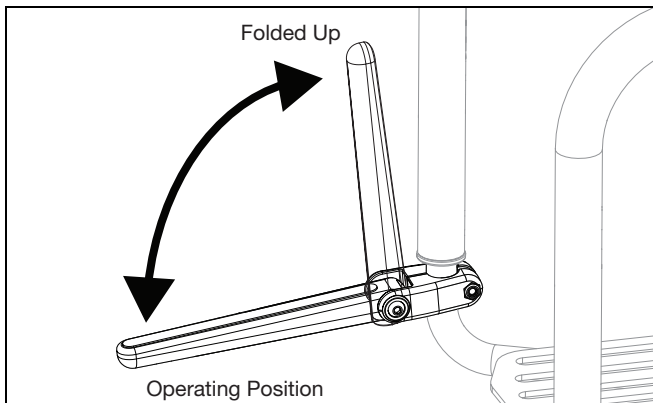

Handrim Configurations

NOTE: Not all wheels listed below are available for specific models. See an order form or the online parts manual for more information on your specific chair model.

Wheel		Handrim Connection				Handrim							
Wheel	Wheel Part No.	Connection Points	Tab	Spacer*	Screw*	Aluminum Anodized	Superlight	Plastic Coated	Projection	Natural Fit Standard	Natural Fit LT	Flex Rim	
18" MAXX Spoke	109285	3	100698 (Not used w/ Superlight Handrim)	100653 (Not used w/ Superlight Handrim)	Aluminum, Plastic Ctd, Projection: 100654	100206		101106					
20" MAXX Spoke	108244				200536		200542						
22" MAXX Spoke	105135	6	100698 (Not used w/ Superlight Handrim)	100653 (Not used w/ Superlight Handrim)	Natural Fit: 100835	100560		100576	100569	200538	200201		
24" MAXX Spoke	105136				200349	101161	100577	200547	100793	200202			
25" MAXX Spoke	107436				200350		101870	200548	200539	200540			
26" MAXX Spoke	107437				200351		100578	200549	100907	101454			
20" MAXX Mag	111853	6		100629	Aluminum, Plastic Ctd, Projection: 103545	200536		112819					
22" MAXX Mag	111854				100560		112820	112824	200538	200201			
24" MAXX Mag	111855				105137		112821	112825	100793	200202			
24" Superlight	101159	6			100536	100754	101161	100836		100830	100828		
25" Superlight	101160				101160	101091	101464	101460					
20" Spinerig Spox	See Spinerig Spox Page	6			Screw: 100669 Nut: 100657	103125		103179					
22" Spinerig Spox						100827	100808	100889	100888				
24" Spinerig Spox						100766	100615	100830	100828				
25" Spinerig Spox						100767	101160	101464	100828				
26" Spinerig Spox						101477	101148	200200	100950				
22" Spinerig LX	See Spinerig LX Page	6			Screw: 100669 Nut: 100657	100827		100808		100889	100888		
24" Spinerig LX						100766	100615	100830	100828				
25" Spinerig LX						100767	101160	101464	100828				
26" Spinerig LX						101477	101148	200200	100950				

Handrim Construction

The sequencing of hardware for the three styles of handrims is shown below. The specific hardware used is determined in the chart on the previous page, based on the tire and handrim being used.

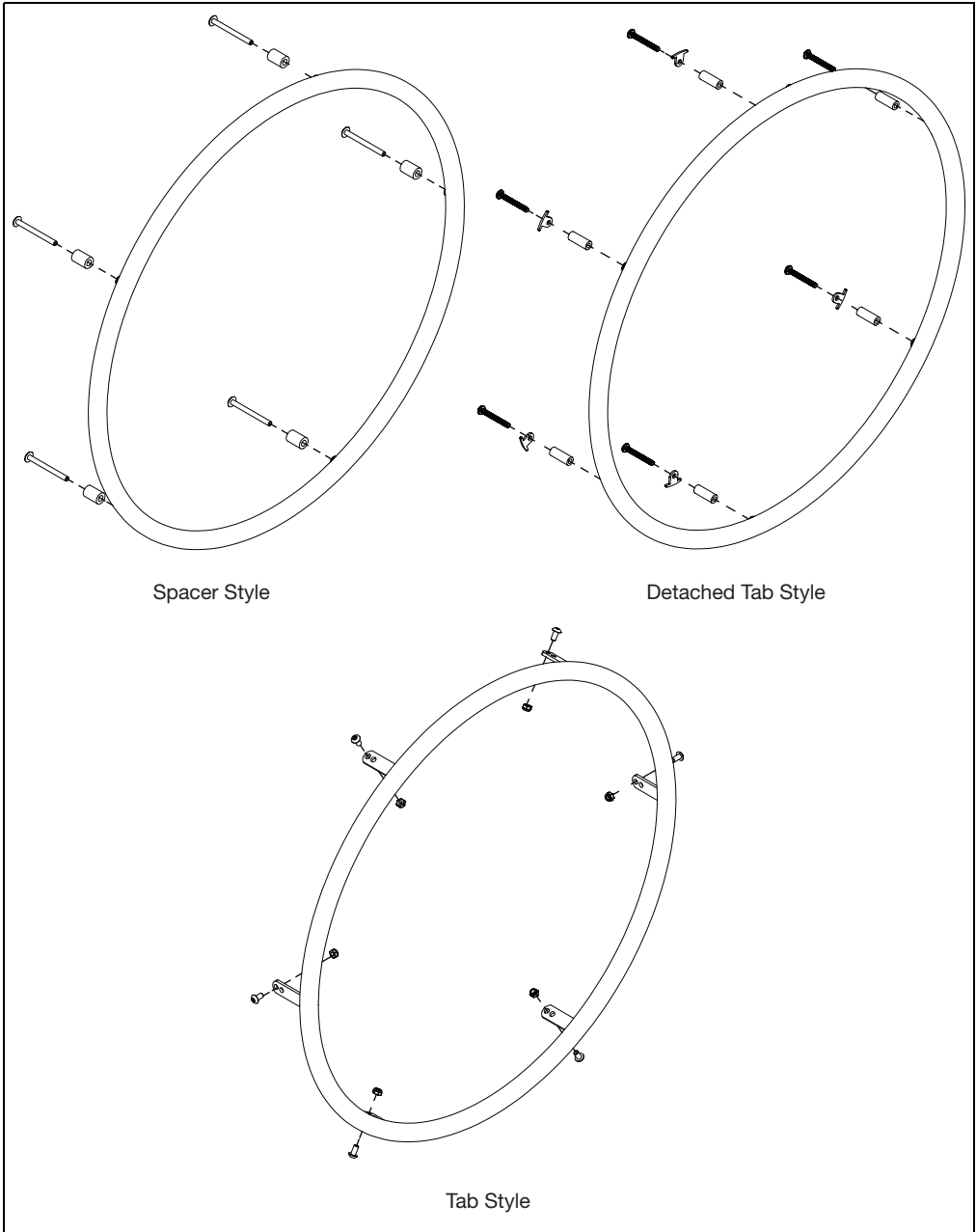

Seat Pan

NOTE: Remove any current seating or cushions before installing the seat pan.

3. Install the seat pan (B) onto the chair frame and secure with screws (A) using a Phillips screwdriver.
4. If not already done, install the tape onto the seat as shown in the image below. The tape should cover as much area as possible without hanging over the edge or covering one of the screw holes.

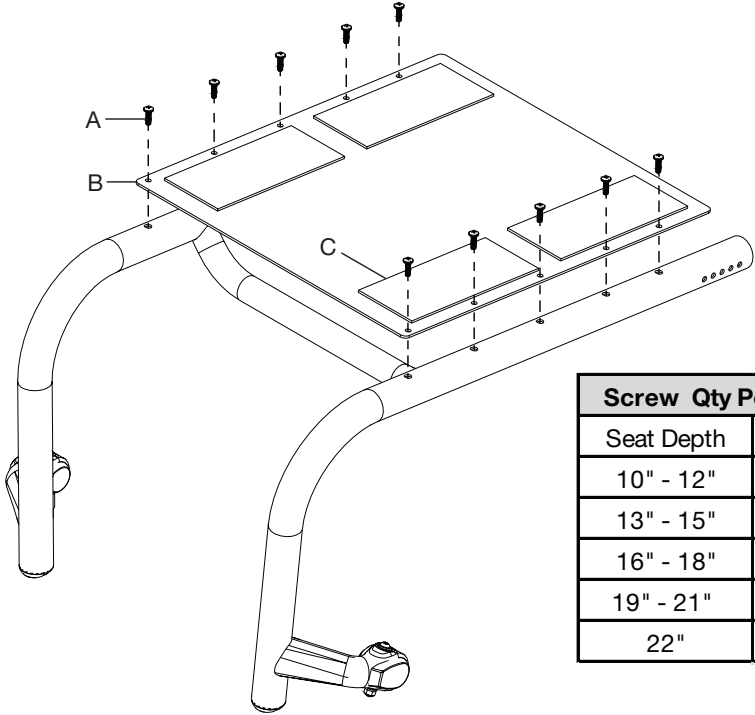

Screw Qty Per Chair	
Seat Depth	Screw Qty
10" - 12"	6
13" - 15"	8
16" - 18"	10
19" - 21"	12
22"	14

Part Number	Tape Size	Seat Pan Depth
004458	3" X 4"	10" - 11"
004458 & 004459	3" X 4" & 3" X 5"	12"
004459	3" X 5"	13"
004460	3" X 6"	14" - 22" (19" - 22")

Seat Upholstery

1. Install the seat rail (B) into the sleeve on the edge of the seat upholstery (C). Repeat on opposite side. The seat rail is shown outside of the sleeve to show the hole alignment in the image below.
2. Secure the seat rail and seat upholstery onto the chair frame with screws (A) using a Phillips screwdriver.

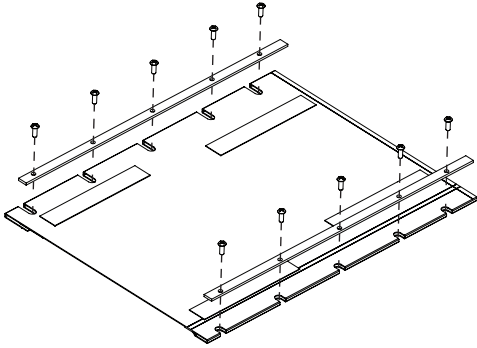

Seat sling used on 10" - 13" wide

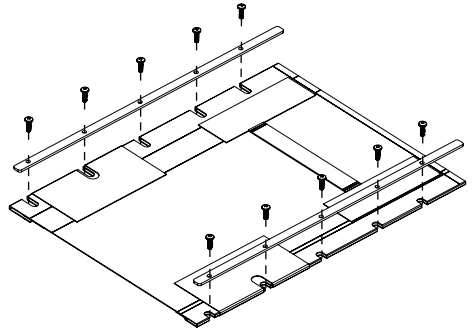

Seat sling used on 14" - 22" wide

SCREW (ITEM 3) QTY PER CHAIR	
SEAT DEPTH	SCREW QTY
10" - 12"	6
13" - 15"	8
16" - 18"	10
19" - 21"	12
22"	14

Side Guards

Side Guard Receiver

1. There are three types of side guard receivers that may be used. The mounted side guard receiver (B) is installed onto the frame with screw (A), washer (C) and nut (D) using a 4mm Allen wrench and a 10mm wrench. The clamp side guard receivers (G & H) are installed onto the frame with two screws (E) and two washers (F) using a 5mm Allen wrench. The anti-rattle side guard receiver (I) is installed the same way as the clamp side guard receiver, it just has two additional rubber buttons (J) installed into the receiver. Repeat on opposite side.

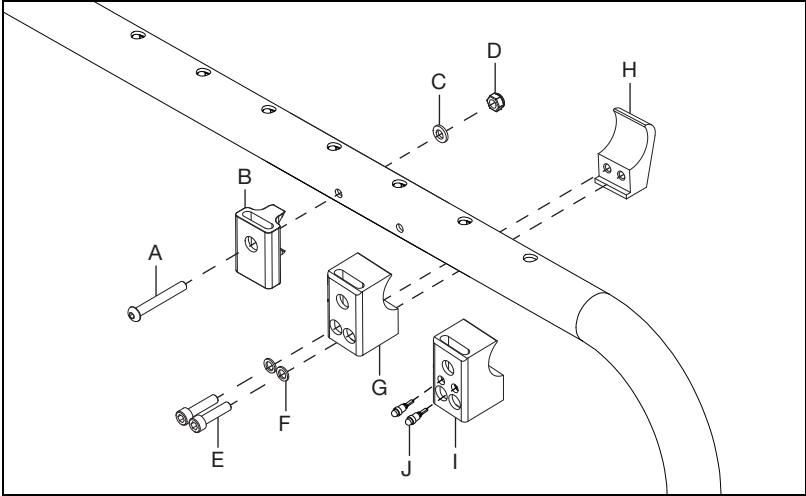

Removable Adult Side Guard

1. Install the adult side guard (D) onto the side guard post (C) with two screws (A) using a 4mm Allen wrench. On the opposite side, install the side guard post stop (B) with a screw (A) using a 4mm Allen wrench.

NOTE: There are two sets of holes that the side guard post (C) can be installed onto the side guard with. Choose the holes that place the side guard in the desired position. The height is also adjusted with the hole that the side guard post stop (B) is installed in.

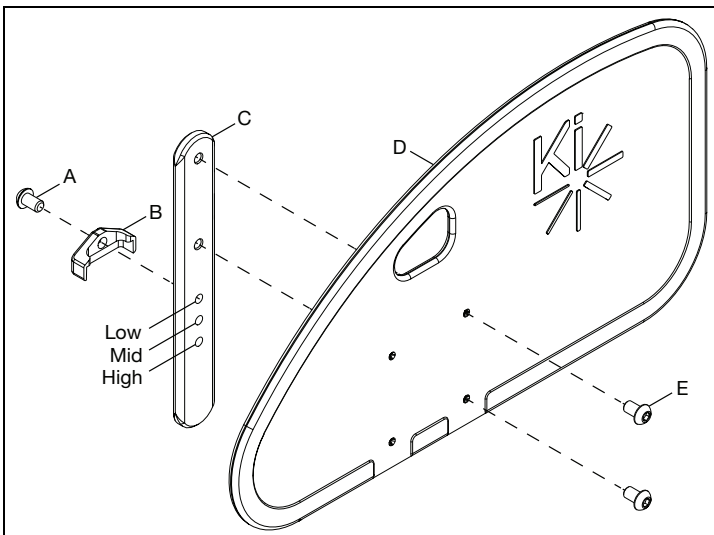

Side Guards

2. Install the side guard assembly into the receiver so the side guard post stop faces the outside of the chair.

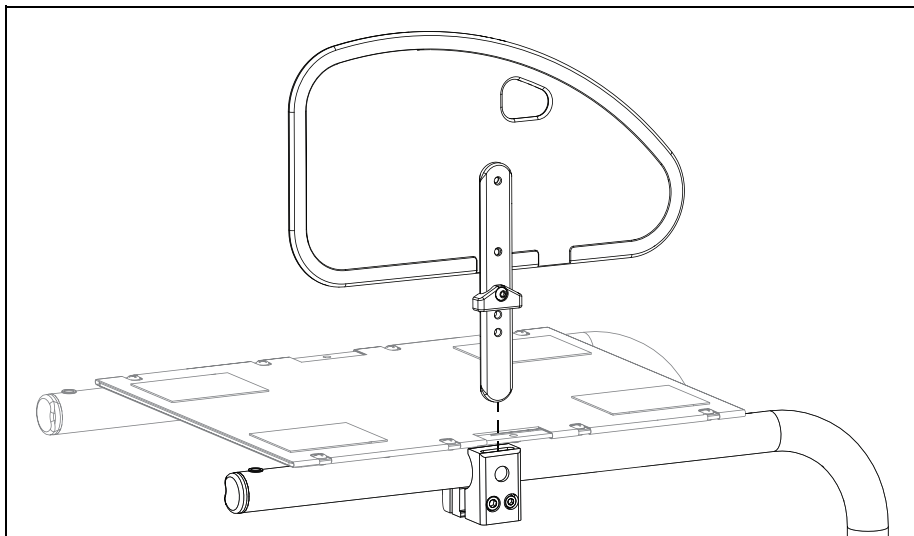

Side Guards

Adjustable Fender Side Guard

1. Install post (B), post mount plate (A) and bolts (D) onto the fender (C) using a 3mm Allen wrench.

NOTE: There are three mounting positions that can be used. Pick the holes that put the fender in the desired position for the occupant. This can be adjusted again later.

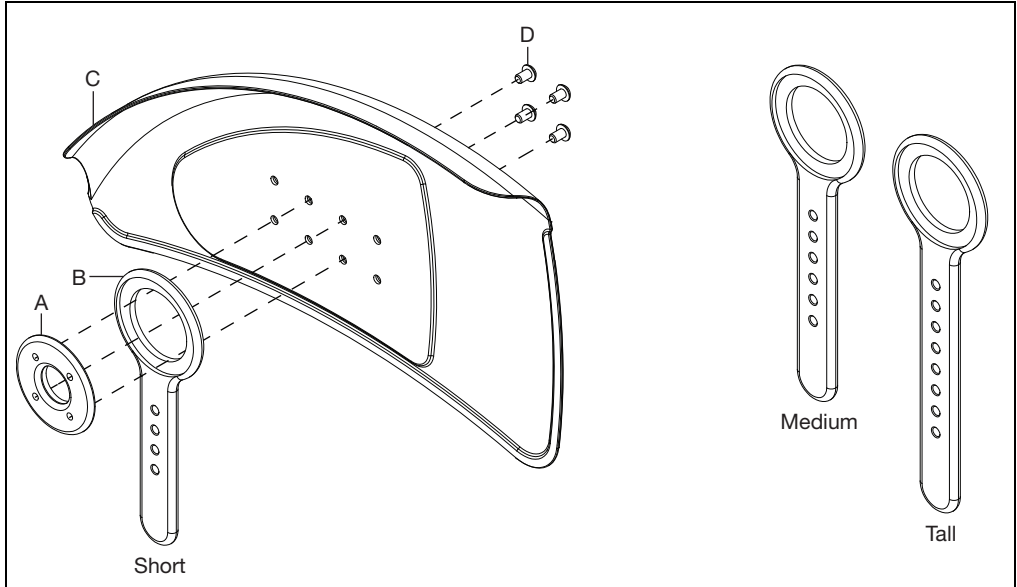

2. Set the height of the back post by installing the post stop (B) with a screw (A) using a 4mm Allen wrench. The height of the post can also be adjusted later if needed.

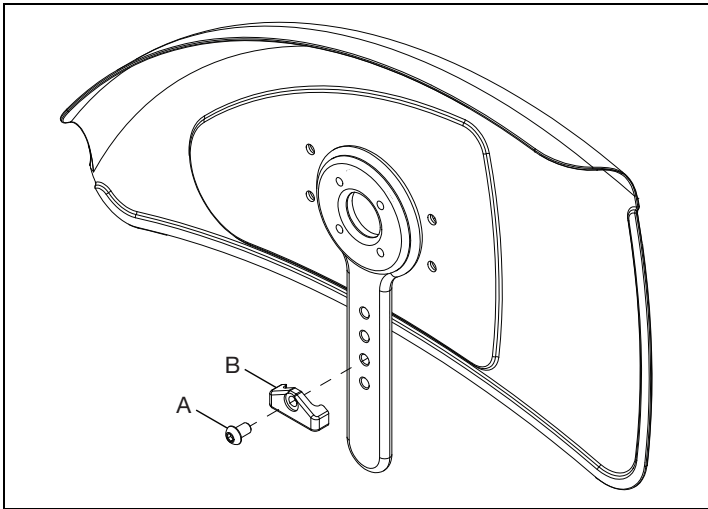

3. Install the fender assembly into the receiver by dropping the post into the receiver slot. Adjust the fender if needed.
4. Repeat steps on opposite side.

Side Guards

Angle Adjustments

The angle of the fender can also be changed to align the fender with the profile of the tire if needed.

1. Remove the four bolts from the post mount with a 3mm Allen wrench.
2. Rotate the fender, either way, to align the fender with the profile of the tire.
3. Rotate the post mount plate so the four holes align with the desired holes on the fender.
4. Reinstall the the four bolts securing the fender to the post and post mount plate using a 3mm Allen wrench.

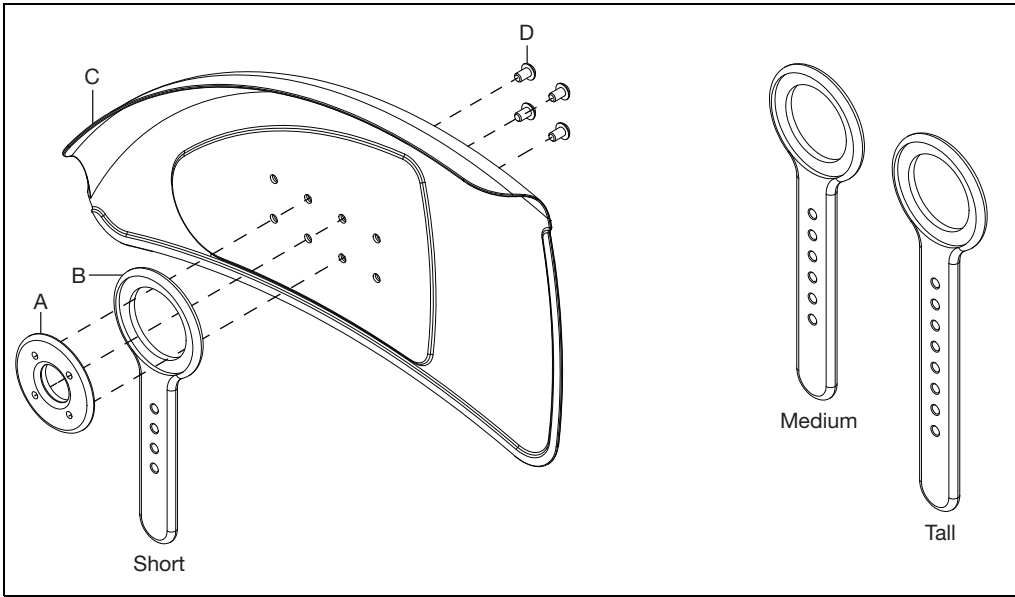

Transit

NOTE: See the Backrest section of this technical manual for full instructions on how to install the transit back plate. An exploded image is shown below as reference, but the full instructions are found in the Backrest section.

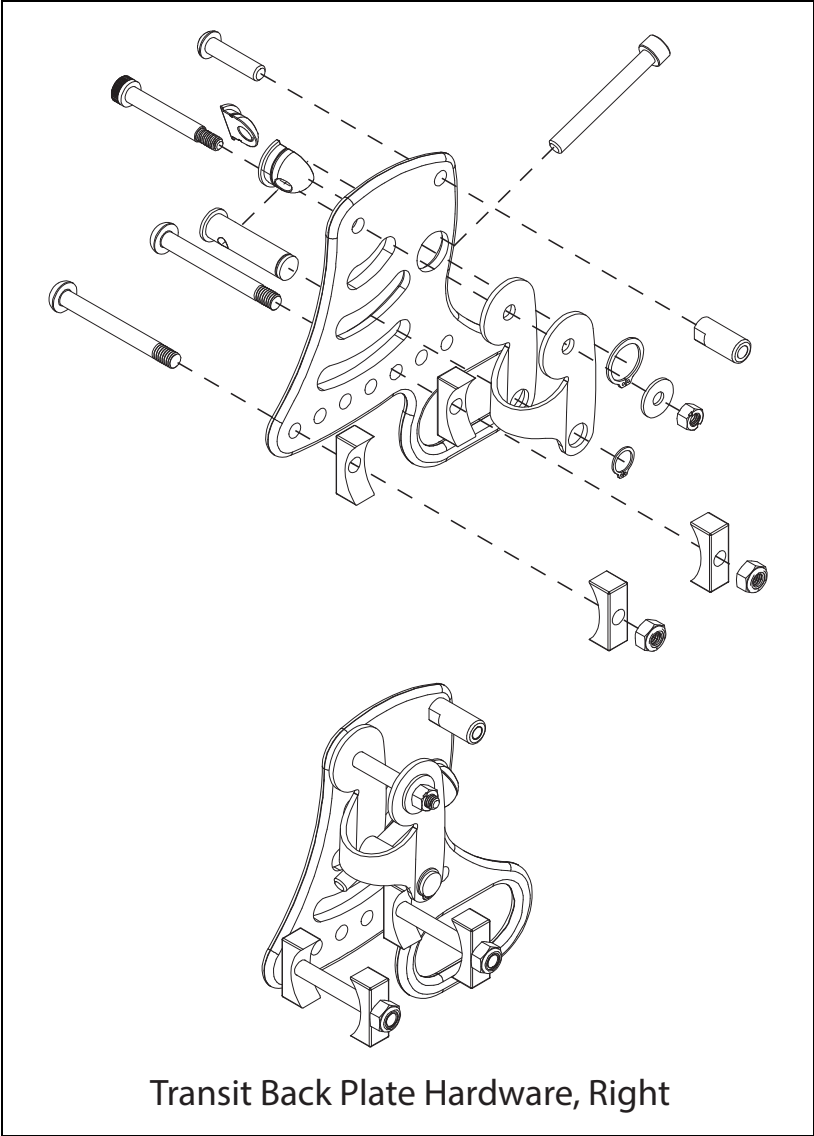

Hybrid Angle Adjustable Footrest

Angle Adjustment of Your Footrest

1. Loosen the two set screws (A) on the bottom of the footrest using a 4mm Allen wrench.
2. Rotate footrest to desired angle and secure in place by retightening the two screws.

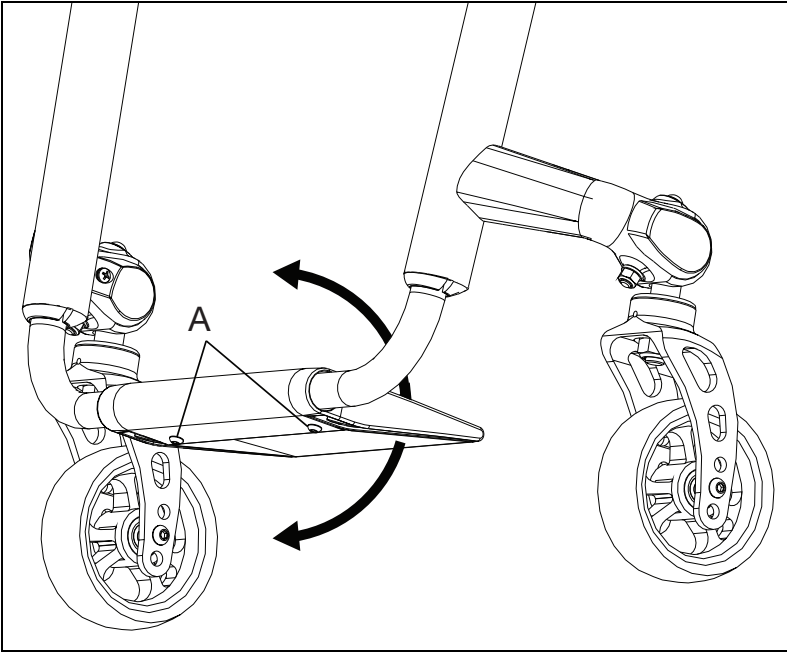

Angle Adjustable Footrest

1. Install the footrest extension tubes (A) into the footrest adjustable clamp (G).
2. Install the footplate (E) onto the clamp and secure with two screws (D) and two nuts (H) using a 5mm Allen wrench and a 10mm wrench. If a riser (F) is being used to elevate the footrest platform, install between the footrest platform and the footrest adjustable clamp.
3. Install the footrest protectors (C) by peeling the backing off of the tape (B) and sticking the tape inside the footrest protector. Peel the remaining backing off of the tape and snap footrest protectors onto the footrest as seen below.

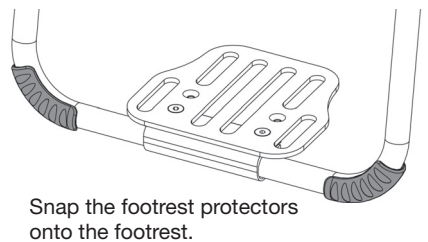
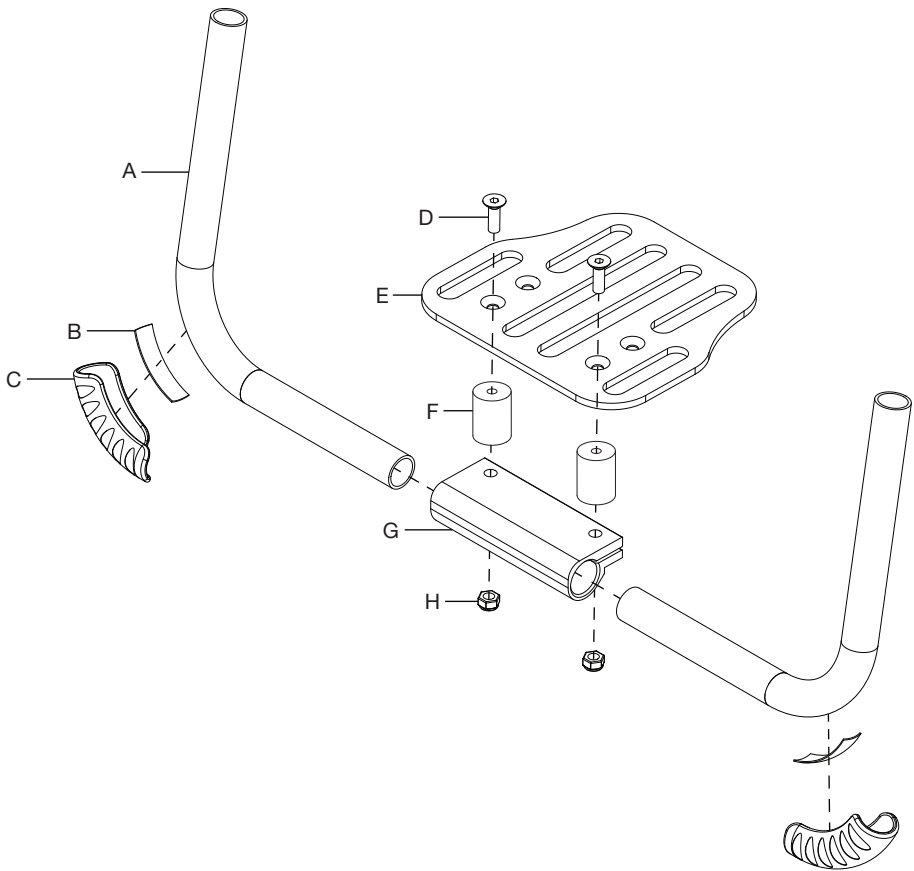

Angle Adjustable Flip Under Footrest

1. Install the footrest tubes (A & D) through the pivots (B) into the footrest flip stop clamp (C).

NOTE: The footrest tube and the footrest tube offset are shown below. The installation process is the same for both footrest tubes.

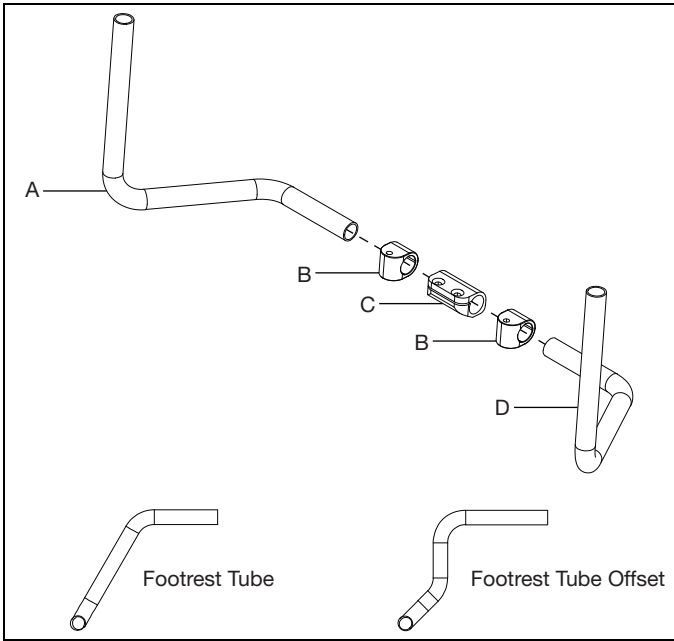

2. Install two screws (C) into the footrest flip stop clamp to secure the footrest tubes using a 5mm Allen wrench. Install the footrest platform (B) onto the footrest flip stop clamp with two screws (A) and two nuts (D) using a 5mm Allen wrench.

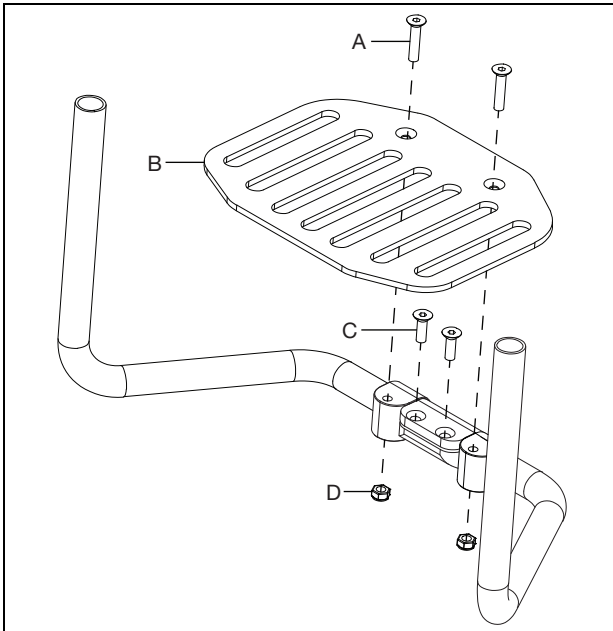

High Mount Angle Adjustable Footrest

1. Install the footrest tubes (A) into the footrest adjustable clamp (B) and secure by installing the footrest platform (C) onto the clamp with two screws (D) and two nuts (E) using a 5mm Allen wrench.

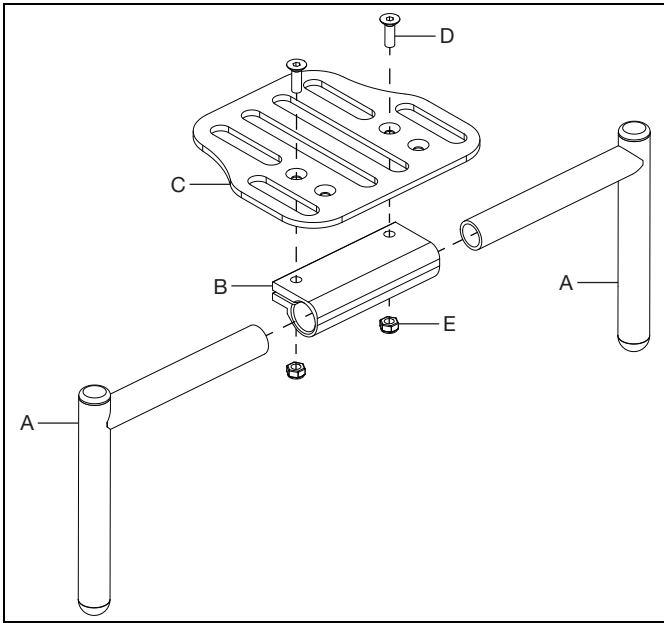

2. Install the two clamps (C & D), one end on the footrest tube and the other end around the frame tube, with two screws (A) and two lock washers (B) using a 5mm Allen wrench.

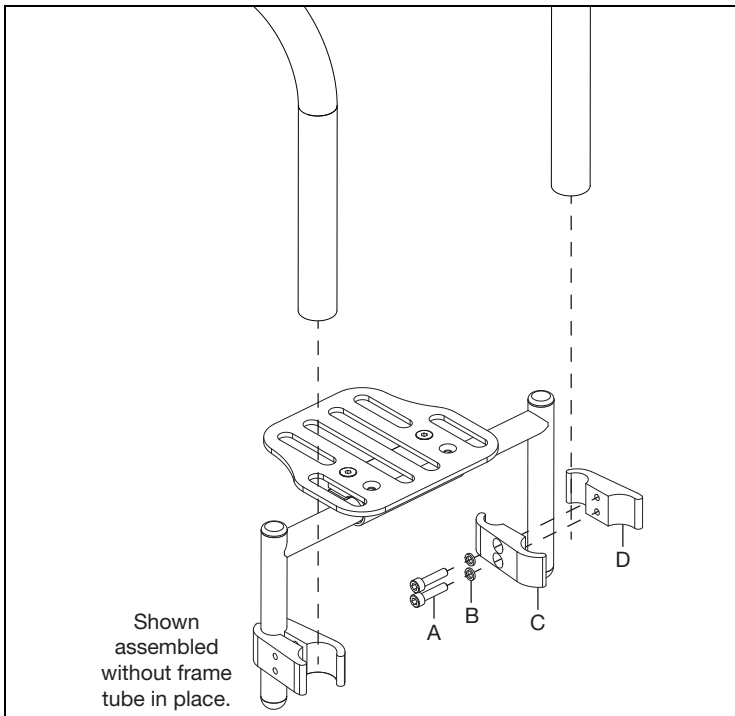

High Mount Angle Adjustable Flip Under Footrest

1. Install the pivots (B) and clamp (D) onto the footrest tube (A) and secure with two screws (C) using a 5mm Allen wrench.
2. Install the bracket (F) onto the end of the footrest tube and secure with screw (E) using a 4mm Allen wrench.
3. Install the footrest flip mount tube (H) onto the bracket with two screws (I) and two saddles (G) using a 4mm Allen wrench.

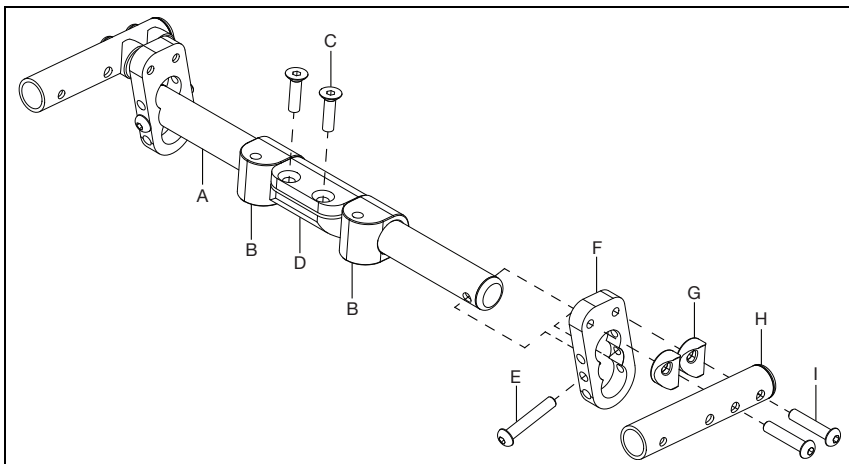

4. Install foot platform (C) onto pivots with two screws (B) using a 5mm Allen wrench. While installing the foot platform, slide the flip foot strap (A) onto frame tube.
5. Install the top and bottom footplate clamps (E & F) onto the footrest tubes and the frame tubes with three screws (D & G) using a 4mm Allen wrench and a 5mm Allen wrench.

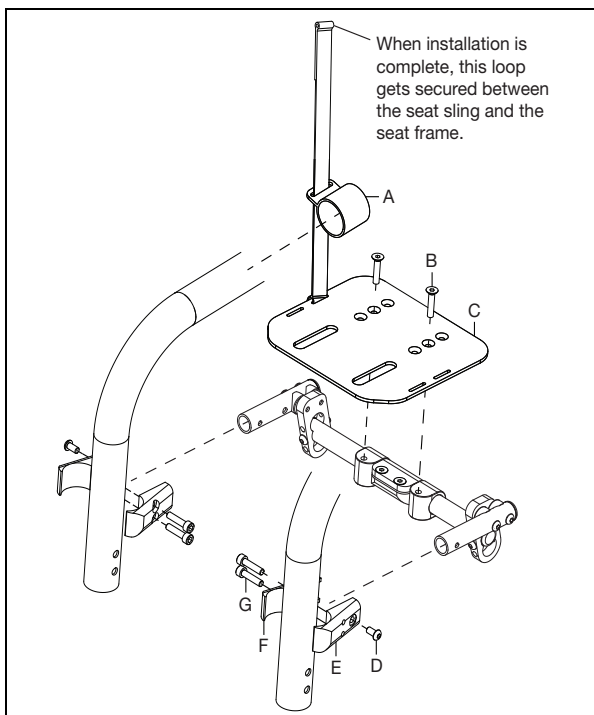

Adjusting the Footrest

NOTE: Some footrests are adjusted by moving the clamps they are attached with up or down. The standard footrest adjustment is shown below.

Height Adjustment of Footrest

1. Locate the set screw on each side of the frame.
2. Loosen the set screw on each side of the frame using a 3mm Allen wrench. Do not remove set screws all the way.
3. Adjust footrest tube up or down to achieve the desired height (B).
4. Ensure both sides are adjusted equally.
5. Retighten each set screw to 40 in./lbs.

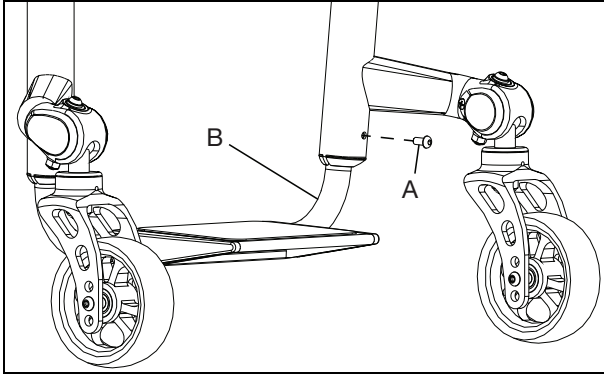

Anti-Tips

1. Assemble the anti-tip by sliding the anti-rattle bushing on (D) and connecting the two anti-tip tubes (B & C), ensuring they "click" together when the detent buttons (A) engage.

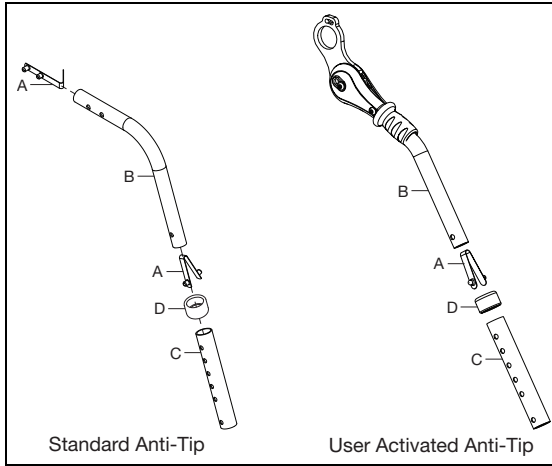

2. Install the wheels (B) onto the anti-tip tube with a bolt (C) and nut (A) using two 10mm wrenches.

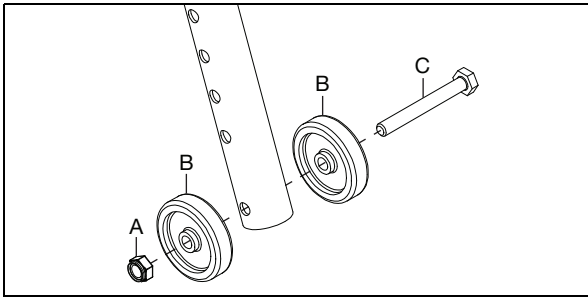

3. The anti-tip receivers are installed on the base mounts and the camber tube runs through the receivers. The standard and user activated configurations are shown below. For more specific information, refer to the Index Towers and Camber Tube section in this technical manual.

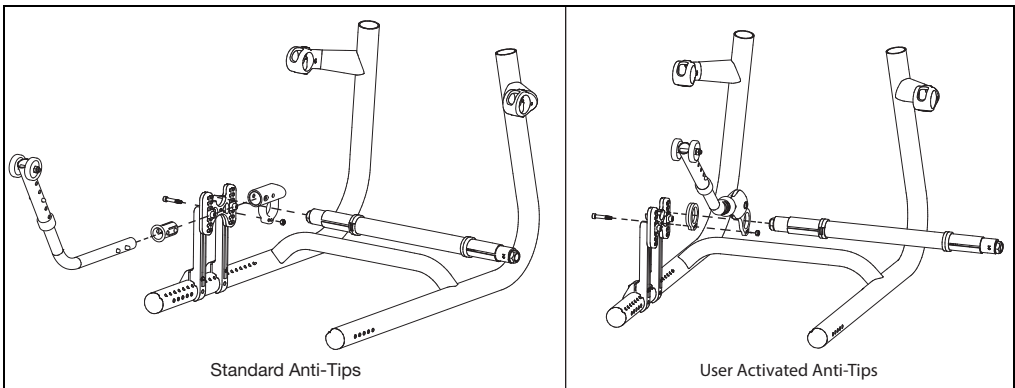

Wheel Locks

See image below for information on the types of wheel locks available. Installation of the wheel lock clamps is on the next page. The Under Seat Scissor Lock always comes assembled so it is not shown below.

Push to Lock Flush Mount

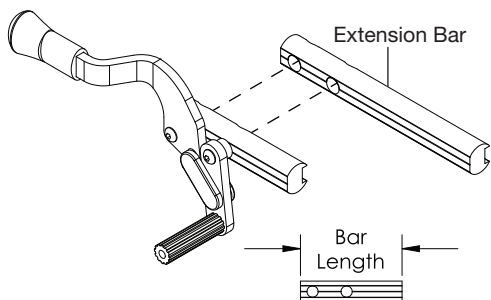

Part #	Bar	Length
N/A	Standard	3.5"
000904	Extended	6.0"

Low Profile Scissor Lock

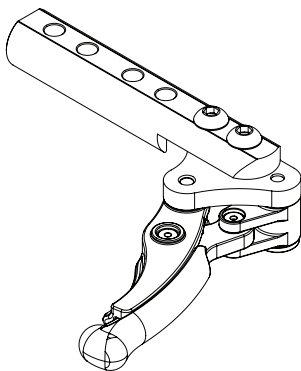

Short Thru Scissor Locks

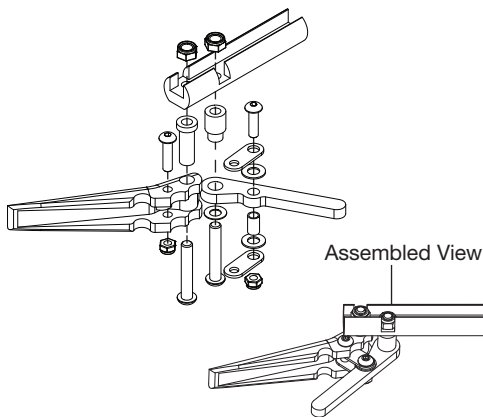

Grade Aids

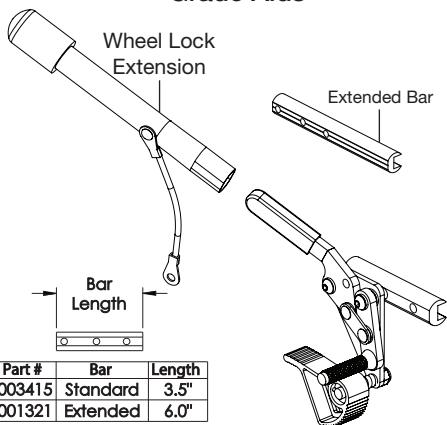

Part #	Bar	Length
003415	Standard	3.5"
001321	Extended	6.0"

Push and Pull to Lock Wheel Locks

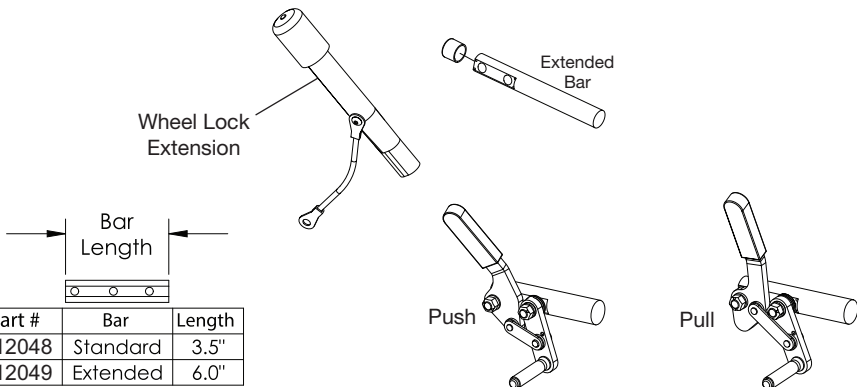

Part #	Bar	Length
112048	Standard	3.5"
112049	Extended	6.0"

Wheel Locks

Installing Wheel Lock Clamps

1. The wheel lock assemblies with the wheel lock bars are mounted onto the chair using the wheel lock clamps (C & D). There are two types of wheel lock clamps that are shown below. Install hardware with the wheel lock bar and chair frame in position using a 5mm Allen wrench and a 6mm Allen wrench. Once installed, ensure wheel lock engages at least 1/8" into tire and locks properly prevent the chair from moving when engaged.

NOTE: Always tighten wheel lock hardware by alternating between hardware while tightening a little at a time. This prevents overclamping on one set of hardware which can lead to binding of the fasteners and increased difficulty in removal.

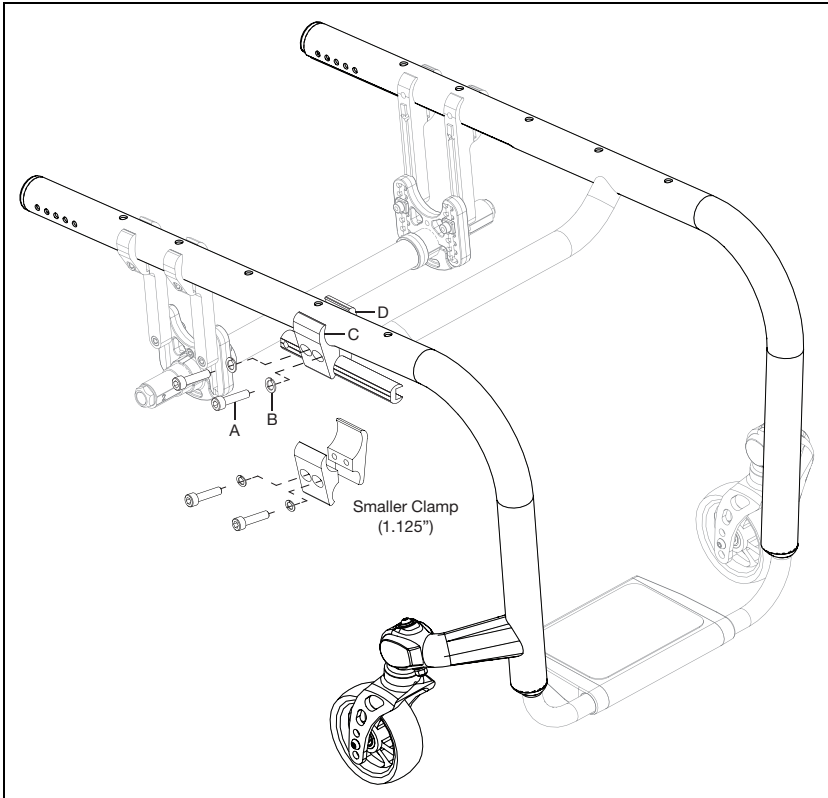

Reversing Wheel Lock

1. Identify the type of wheel lock on the chair.

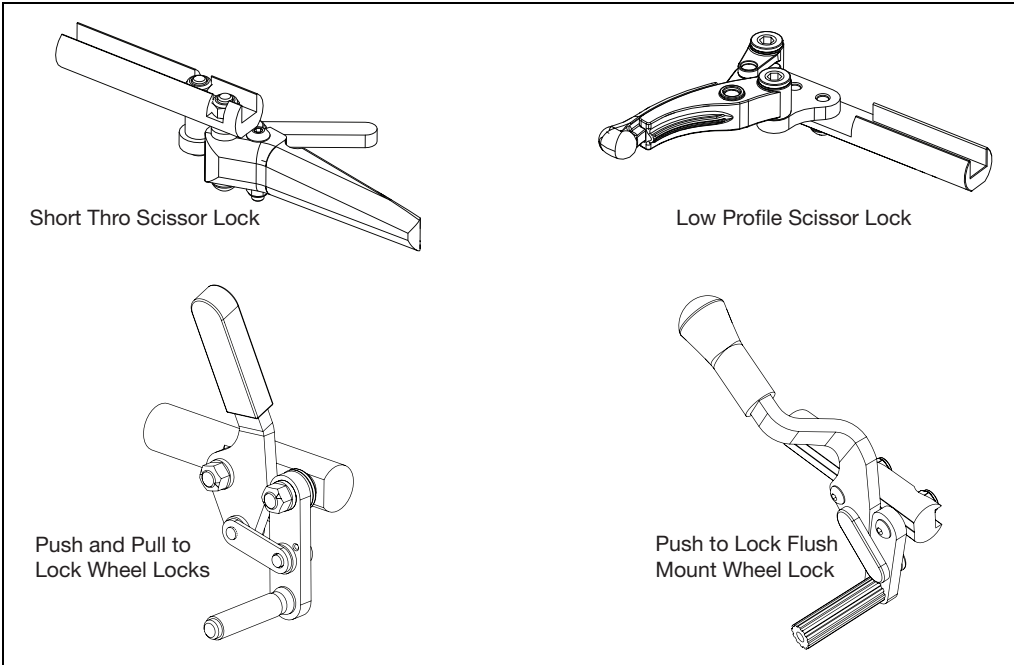

2. Remove wheel lock (D) and wheel lock bar (E) from clamp (C) by removing the two bolts (A) and two lock washers (B) with a 5mm Allen wrench.

NOTE: The push to lock flush mount is shown below. The process of removing the clamp is the same for all of the wheel locks.

NOTE: Always loosen wheel lock hardware by alternating between the two bolts while loosening a little at a time. This prevents overclamping on one set of hardware which can lead to binding of the fasteners and increased difficulty in removal.

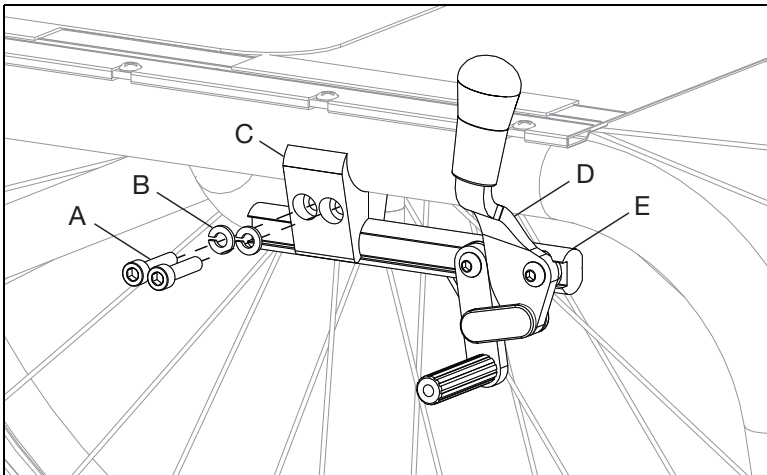

Reversing Wheel Lock

3. Remove the wheel lock assembly from the wheel lock bar. For a low profile scissor lock, use a 5mm Allen wrench to remove the two bolts. For the short throw and push to lock flush mount, remove hardware using a 4mm Allen wrench and a 10mm wrench. For the push and pull to lock, loosen and remove the top lock nuts and then grasp the assembly so the spring does not come out of the linkage hole when sliding off the arbors.

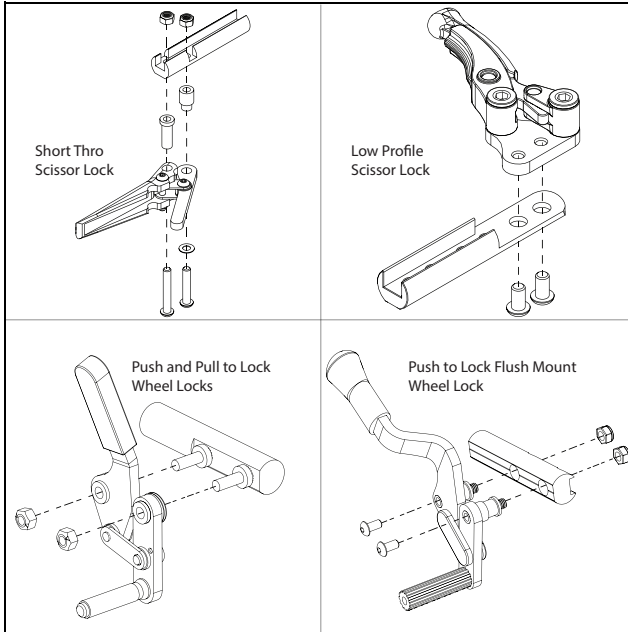

4. Rotate the wheel lock bar 180°.

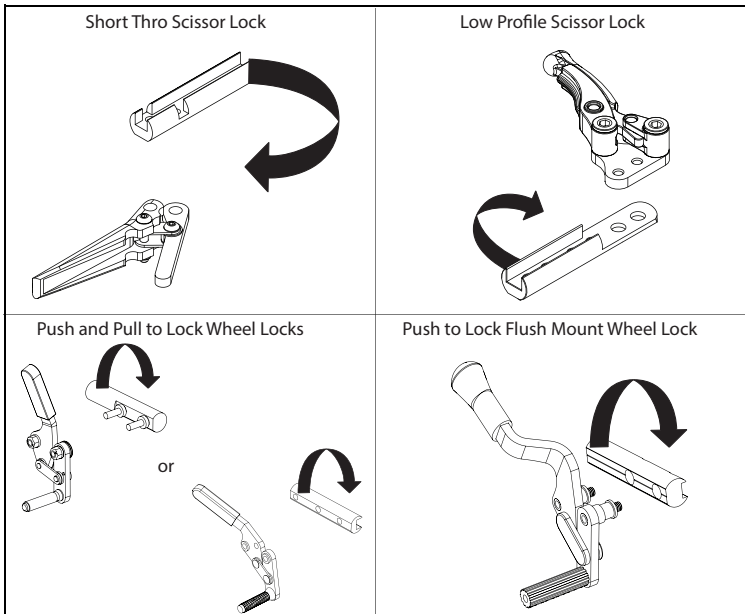

Reversing Wheel Lock

5. Reinstall the wheel lock assembly onto the wheel lock bar. For a low profile scissor lock, use a 5mm Allen wrench to install the two bolts. For the short throw and push to lock flush mount wheel locks, install hardware using a 4mm Allen wrench and a 10mm wrench. For the push and pull to lock, slide the assembly back onto the arbors. To install the spring on a push to lock, pull the curved spring arm over the arbor shoulder. To install the spring on a pull to lock, pull the spring arm end into the wheel lock bar hole (thin screwdriver will help with this). Place and tighten the top lock nuts to secure. See image below.

NOTE: Always tighten wheel lock hardware by alternating between the two bolts while tightening a little at a time. This prevents overclamping on one set of hardware which can lead to binding of the fasteners and increased difficulty in removal.

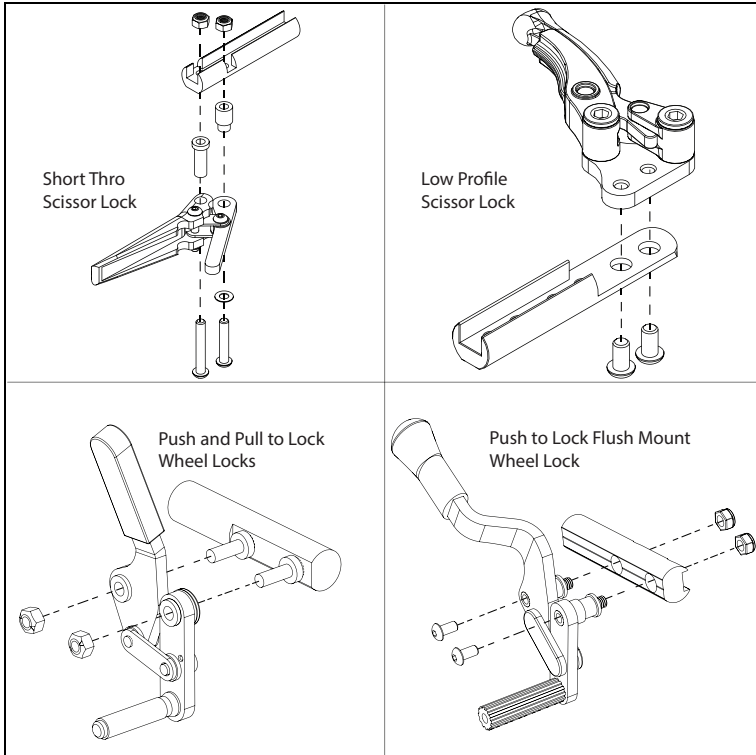

6. Test the wheel locks. Ensure wheel lock arms embed in tires at least 1/8 inch when locked. If they do not embed at least 1/8 inch, readjust wheel lock and test again.

Center of Gravity Adjustment

You can adjust your center of gravity by moving the two rear tower index clamps (A) forward or rearward on the seat tube (B). Moving the rear tower index clamps forward shortens the wheelbase and lightens the front end, making your chair more maneuverable. Moving the rear tower index clamps rearward makes the chair more stable and less likely to tip over rearward.

NOTE: Changes to the center of gravity may affect the rear seat height, toe-in/toe-out of the rear wheels and the squareness of the casters. If you change your center of gravity position, readjust all of these settings as necessary.

NOTE: Adjusting your chair's center of gravity will require readjusting the location of the wheel locks (if provided). See the Wheel Lock section for instructions on adjusting the wheel locks.

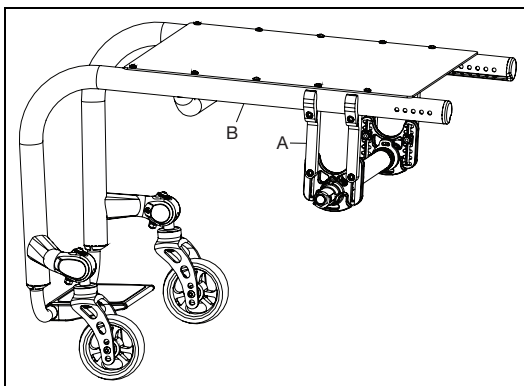

To adjust the center of gravity location:

- Remove both rear wheels.
- Loosen the two bolts at the top of the rear index clamps on both sides of the chair using a 4mm Allen wrench.
- Slide the rear index clamps and assemblies along the frame to the desired position.
- Ensure the rear index clamps on both sides of the frame are adjusted equally on both sides of the frame before retightening the clamps.
- Once the rear index clamps are secured, attach the rear wheels, occupy the chair and maneuver it with a spotter to get a feel for the new adjustment.

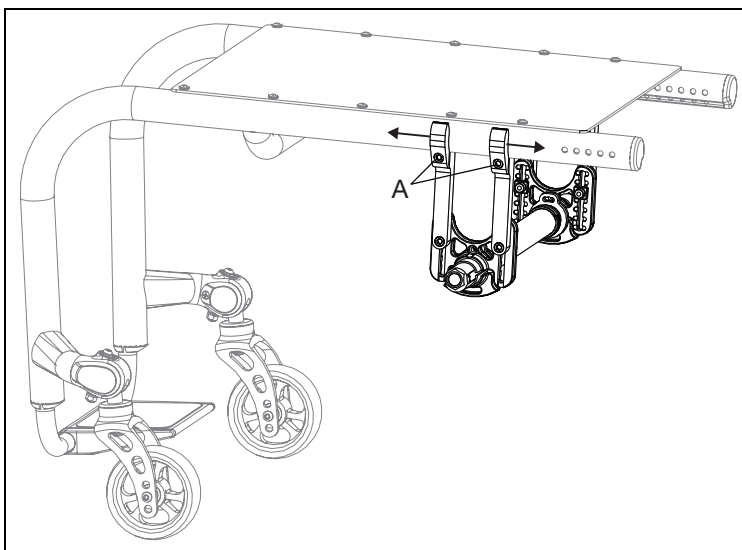

Seat Height Adjustment

Rear Seat Height

Rear seat height can be adjusted by repositioning upper base mounts.

1. Remove your wheels by depressing the buttons on the quick release axle. For easier access, flip the chair upside down.
2. Use a 4mm Allen wrench to remove the two bolts (D), two washers and two square nuts (A) per upper base mount.
3. Reinstall the hardware in the new desired seat height hole on the upper base mount.
4. Repeat on both sides of the wheelchair.
5. When the desired height is reached, tighten the bolts (D) to 70 in./lbs.

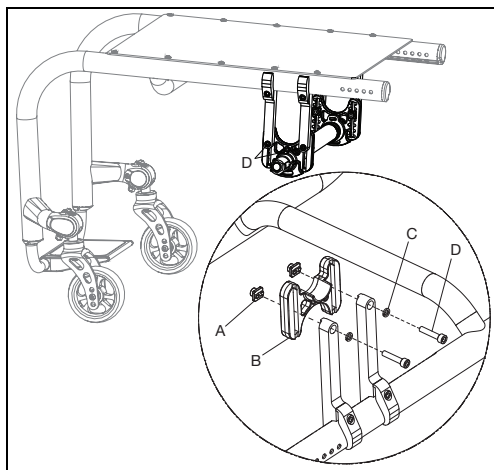

NOTE: Height adjustments are in $\frac{1}{4}$ " increments.

NOTE: A front caster adjustment should be made to correspond with any change in seat angle.

Front Seat Height

The front seat height can be adjusted in $\frac{1}{2}$ " increments by repositioning the caster wheel within the fork.

1. Use two 4mm Allen wrenches to remove the cap screws and push the internally threaded axle from one hole location and move up or down to the desired location.
2. Reposition the two 6mm screws and tighten to 80 in./lbs.
3. Resquare caster wheels.

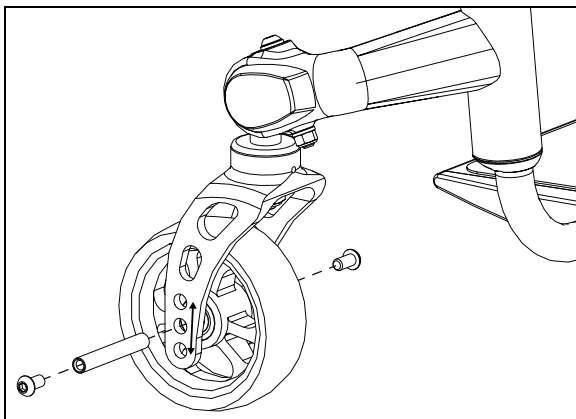

Setting Toe to Zero

NOTE: A wheelchair equipped with 0° camber plugs cannot have a toe-in toe-out condition. This adjustment is only required when using 2°, 4°, 6° and 8° camber adapters.

Toe refers to how well the rear wheels of the chair are aligned relative to the ground. It affects how well the chair will roll. Drag or rolling resistance is optimally minimized when the wheel toe is set to zero.

To Set Toe to Zero:

1. Remove the lower base mounts by removing two bolts per side using a 3mm Allen wrench. If anti-tips are present, the image will look different, but the process is the same.
2. Adjust the camber tube so it is centered in the mounts and rotate the tube until the camber is facing upward, relative to the ground if the chair is upright.
3. Reinstall the lower basemounts with the hardware loose.
4. Tighten the bolts in the sequence shown below (1,2,3,4) to 70 in/lbs.

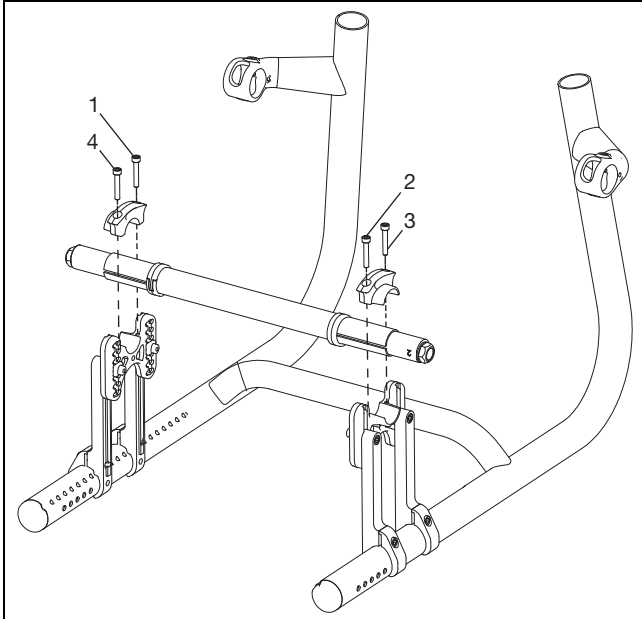

Wheelbase Width Adjustment

Adjusting the wheelbase width allows the rider the option to move the wheels closer or further away from the hips. It also compensates for camber adjustment and gives the proper wheel spacing to maximize pushing efficiency.

To Adjust the Wheelbase Width

1. Remove the lower base mounts (B) by removing two bolts (A) per side using a 3mm Allen wrench. If anti-tips are present, the image will look different, but the process is the same.
2. Move the dimple clip (C) to the dimple on the camber plug (D) that provides the desired spacing.
3. Repeat on opposite side.
4. When both sides are spaced equally, tighten the bolts (A) to 70 in/lbs.

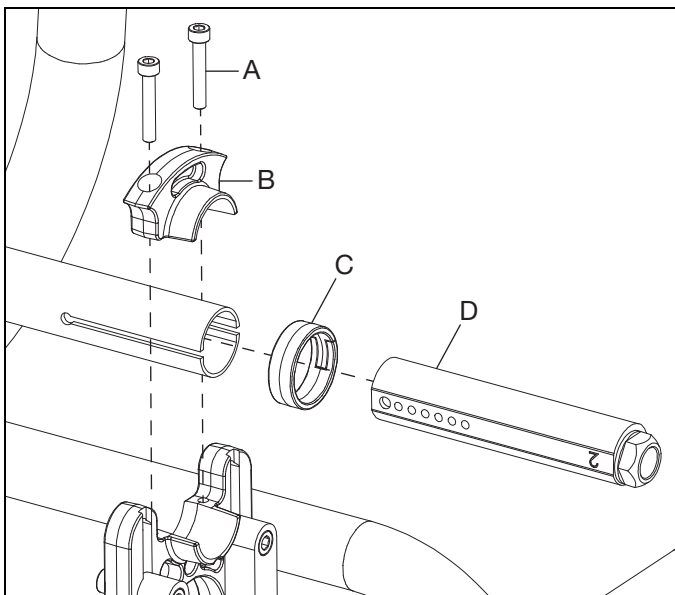

One Arm Drive (OAD)

Installation

1. Remove wheels, camber tube and index tower assembly by removing two bolts (A) at the top of the index towers on each side using a 4mm Allen wrench.

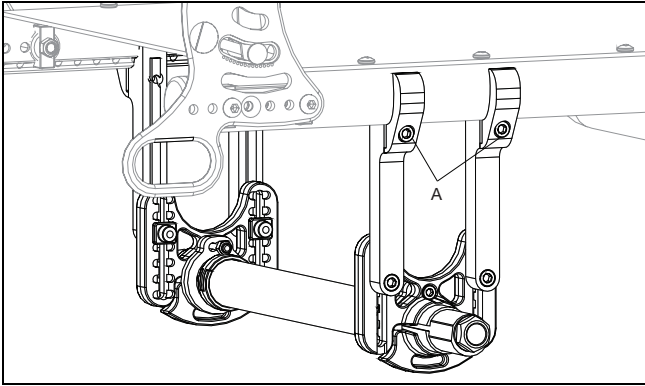

2. Install the camber towers (A) using two bolts and two nuts per side with a 3mm Allen wrench and an 8mm wrench. The location of these camber towers along the seat frame determines COG.
3. Install the camber tube mount clamps (F) onto the camber towers (A) using three bolts (D & B) and three nuts (E) using a 4mm Allen wrench and an 8mm wrench. The holes used to install the camber mount clamp onto the camber tower determines seat height for the user.
4. The axle mount (C) must be mounted reverse of how it is shown in the image below when using 2 degrees or greater camber. Remove the bolt (B) and nut (E) using a 4mm Allen wrench and an 8mm wrench, reverse the axle mount and reinstall hardware.

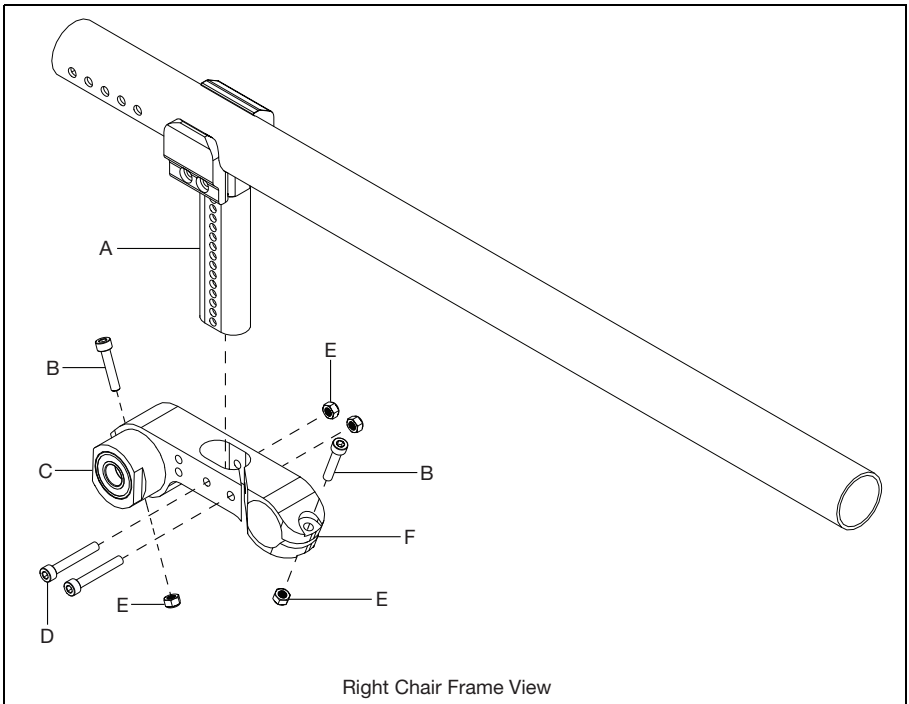

One Arm Drive (OAD)

4. Install the camber mount clamp on the opposite side the same way as steps 2 and 3. Before fully tightening, install the OAD drive shaft (A) into the two axle mounts.

NOTE: See tables at the end of these instructions for the drive shaft lengths used in different configurations.

NOTE: Some configurations require one wheel to be installed, then the drive shaft, then the opposite wheel. These configurations are called out in the Shaft Reference at the end of these instructions.

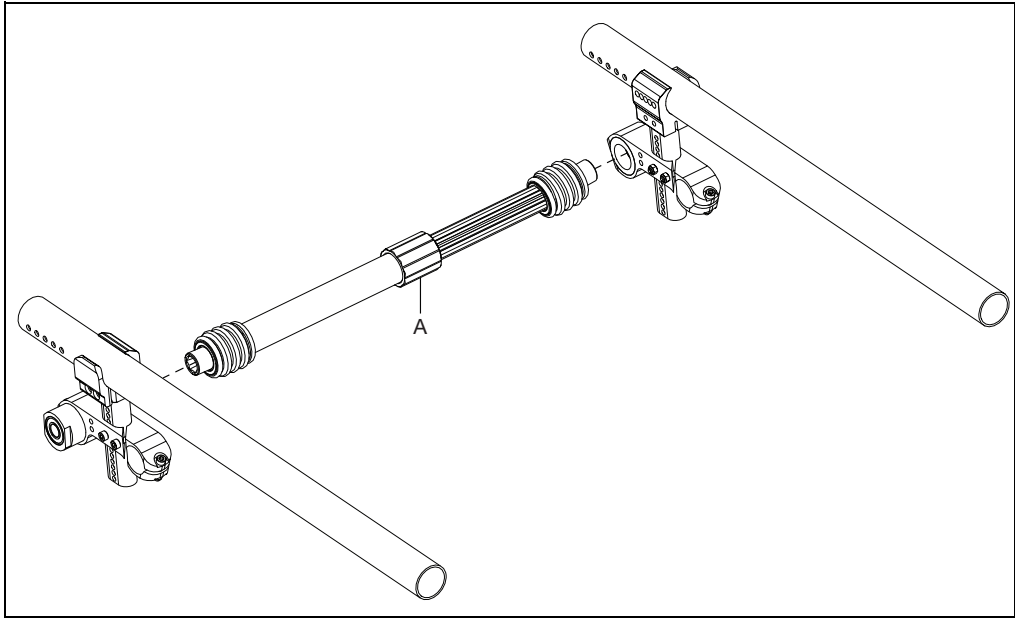

5. Install the OAD wheels on both sides of chair. Install the OAD wheel with the handrim (A) on the desired drive side. The OAD wheel with no handrim (B) is the following side and is installed opposite the drive wheel.

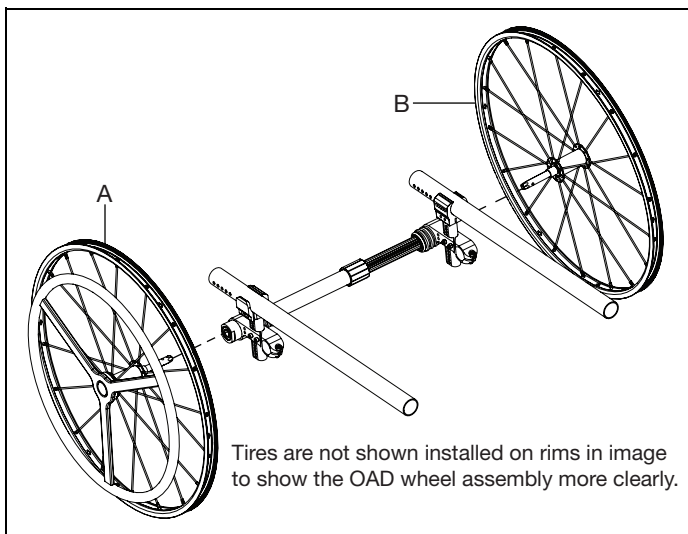

Tires are not shown installed on rims in image to show the OAD wheel assembly more clearly.

One Arm Drive (OAD)

DRIVE SHAFT LENGTH BY CONFIGURATION				
ROGUE SEAT WIDTH	WHEEL SPACING	CAMBER	DESCRIPTION	PART NUMBER
SEAT WIDTH 11"	1.75	0	QUICK RELEASE OAD ZERO CAMBER DRIVE SHAFT 177-255MM	-111503
	0.75, 1	2	QUICK RELEASE OAD UNIVERSAL DRIVE SHAFT 170-190MM	#111858
	1.25	2	QUICK RELEASE OAD UNIVERSAL DRIVE SHAFT 190-210MM	#111827
	1.5	2	QUICK RELEASE OAD UNIVERSAL DRIVE SHAFT 195-230MM	#111628
	1.75	2	QUICK RELEASE OAD UNIVERSAL DRIVE SHAFT 195-235MM	-111828
SEAT WIDTH 12"	1.5	4	QUICK RELEASE OAD UNIVERSAL DRIVE SHAFT 195-235MM	#111828
	1.5	0	QUICK RELEASE OAD ZERO CAMBER DRIVE SHAFT 177-255MM	111503
	1.75	0	QUICK RELEASE OAD ZERO CAMBER DRIVE SHAFT 177-255MM	-111503
	0.75, 1	2	QUICK RELEASE OAD UNIVERSAL DRIVE SHAFT 160-210MM	#111827
	1.25, 1.5	2	QUICK RELEASE OAD UNIVERSAL DRIVE SHAFT 195-235MM	111628
SEAT WIDTH 13"	1.75	2	QUICK RELEASE OAD UNIVERSAL DRIVE SHAFT 220-280MM	-111498
	0.75, 1	4	QUICK RELEASE OAD UNIVERSAL DRIVE SHAFT 195-235MM	111828
	1, 1.25, 1.5	0	QUICK RELEASE OAD ZERO CAMBER DRIVE SHAFT 177-255MM	111503
	1.75	0	QUICK RELEASE OAD ZERO CAMBER DRIVE SHAFT 225-295MM	-111504
	0.75, 1	2	QUICK RELEASE OAD UNIVERSAL DRIVE SHAFT 195-235MM	111828
SEAT WIDTH 14"	1.25, 1.5	2	QUICK RELEASE OAD UNIVERSAL DRIVE SHAFT 220-280MM	111498
	1.75	2	QUICK RELEASE OAD UNIVERSAL DRIVE SHAFT 220-280MM	-111498
	0.75, 1	4	QUICK RELEASE OAD UNIVERSAL DRIVE SHAFT 220-280MM	111498
	1, 1.25	0	QUICK RELEASE OAD ZERO CAMBER DRIVE SHAFT 177-255MM	111503
	1.5	0	QUICK RELEASE OAD ZERO CAMBER DRIVE SHAFT 225-295MM	-111504
SEAT WIDTH 15"	1.75	0	QUICK RELEASE OAD ZERO CAMBER DRIVE SHAFT 225-295MM	-111504
	0.75, 1, 1.25	2	QUICK RELEASE OAD UNIVERSAL DRIVE SHAFT 220-280MM	111498
	1.5	2	QUICK RELEASE OAD UNIVERSAL DRIVE SHAFT 270-330MM	#111499
	1.75	2	QUICK RELEASE OAD UNIVERSAL DRIVE SHAFT 270-330MM	-111499
	0.75, 1	4	QUICK RELEASE OAD UNIVERSAL DRIVE SHAFT 270-330MM	#111499
SEAT WIDTH 15"	1, 1.25, 1.5	0	QUICK RELEASE OAD ZERO CAMBER DRIVE SHAFT 225-295MM	111504
	1.75	0	QUICK RELEASE OAD ZERO CAMBER DRIVE SHAFT 260-370MM	-111505
	0.75	2	QUICK RELEASE OAD UNIVERSAL DRIVE SHAFT 220-280MM	111498
	1	2	QUICK RELEASE OAD UNIVERSAL DRIVE SHAFT 270-330MM	#111499
	1.25, 1.5	2	QUICK RELEASE OAD UNIVERSAL DRIVE SHAFT 270-330MM	-111499
SEAT WIDTH 15"	1.75	2	QUICK RELEASE OAD UNIVERSAL DRIVE SHAFT 350-400MM	-111500
	0.75, 1	4	QUICK RELEASE OAD UNIVERSAL DRIVE SHAFT 270-330MM	111498

NOTES:

#FOR THIS CONFIGURATION, ONE WHEEL MUST BE REMOVED BEFORE THE DRIVESHAFT CAN BE INSTALLED. THE SECOND WHEEL CAN BE INSTALLED ONCE THE DRIVE SHAFT IS IN POSITION.

#FOR THIS CONFIGURATION, TOWER ASSEMBLIES ARE TO BE MOUNTED OUTBOARD OF THE FRAME.

One Arm Drive (OAD)

DRIVE SHAFT LENGTH BY CONFIGURATION				PART NUMBER
ROGUE SEAT WIDTH	WHEEL SPACING	CAMBER	DESCRIPTION	PART NUMBER
SEAT WIDTH 16"	1	0	QUICK RELEASE OAD ZERO CAMBER DRIVE SHAFT 225-295MM	111504
	1.25, 1.5	0	QUICK RELEASE OAD ZERO CAMBER DRIVE SHAFT 260-370MM	111505
	1.75	0	QUICK RELEASE OAD ZERO CAMBER DRIVE SHAFT 260-370MM	-111505
	0.75, 1	2	QUICK RELEASE OAD UNIVERSAL DRIVE SHAFT 270-330MM	111489
	1.25, 1.5	2	QUICK RELEASE OAD UNIVERSAL DRIVE SHAFT 295-370MM	111500
SEAT WIDTH 16"	1.75	2	QUICK RELEASE OAD UNIVERSAL DRIVE SHAFT 295-370MM	-111500
	0.75, 1	4	QUICK RELEASE OAD UNIVERSAL DRIVE SHAFT 295-370MM	111500
	1, 1.25, 1.5	0	QUICK RELEASE OAD ZERO CAMBER DRIVE SHAFT 260-370MM	111505
	1.75	0	QUICK RELEASE OAD ZERO CAMBER DRIVE SHAFT 330-440MM	-111505
	0.75, 1, 1.25, 1.5	2	QUICK RELEASE OAD UNIVERSAL DRIVE SHAFT 285-370MM	111500
SEAT WIDTH 17"	1.75	2	QUICK RELEASE OAD UNIVERSAL DRIVE SHAFT 350-460MM	-111501
	0.75, 1	4	QUICK RELEASE OAD UNIVERSAL DRIVE SHAFT 295-370MM	111500
	1, 1.25	0	QUICK RELEASE OAD ZERO CAMBER DRIVE SHAFT 260-370MM	111505
	1.5	0	QUICK RELEASE OAD ZERO CAMBER DRIVE SHAFT 330-440MM	111506
	1.75	0	QUICK RELEASE OAD ZERO CAMBER DRIVE SHAFT 330-440MM	-111506
SEAT WIDTH 18"	0.75, 1	2	QUICK RELEASE OAD UNIVERSAL DRIVE SHAFT 285-370MM	111500
	1.25, 1.5	2	QUICK RELEASE OAD UNIVERSAL DRIVE SHAFT 350-460MM	111501
	1.75	2	QUICK RELEASE OAD UNIVERSAL DRIVE SHAFT 350-460MM	-111501
	0.75	4	QUICK RELEASE OAD UNIVERSAL DRIVE SHAFT 295-370MM	111500
	1	4	QUICK RELEASE OAD UNIVERSAL DRIVE SHAFT 350-460MM	111501
SEAT WIDTH 19"	1, 1.25, 1.5	0	QUICK RELEASE OAD ZERO CAMBER DRIVE SHAFT 330-440MM	111506
	1.75	0	QUICK RELEASE OAD ZERO CAMBER DRIVE SHAFT 330-440MM	-111506
	0.75	2	QUICK RELEASE OAD UNIVERSAL DRIVE SHAFT 220-280MM	111488
	1	2	QUICK RELEASE OAD UNIVERSAL DRIVE SHAFT 270-330MM	111489
	1.25	2	QUICK RELEASE OAD UNIVERSAL DRIVE SHAFT 285-370MM	111500
SEAT WIDTH 19"	1.5	2	QUICK RELEASE OAD UNIVERSAL DRIVE SHAFT 350-460MM	111501
	1.75	2	QUICK RELEASE OAD UNIVERSAL DRIVE SHAFT 350-460MM	-111501
	0.75, 1	4	QUICK RELEASE OAD UNIVERSAL DRIVE SHAFT 295-370MM	111500
	1, 1.25, 1.5	0	QUICK RELEASE OAD ZERO CAMBER DRIVE SHAFT 330-440MM	111506
	1.75	0	QUICK RELEASE OAD ZERO CAMBER DRIVE SHAFT 421-491MM	-111507
SEAT WIDTH 20"	0.75, 1, 1.25, 1.5	2	QUICK RELEASE OAD UNIVERSAL DRIVE SHAFT 350-460MM	111501
	1.75	2	QUICK RELEASE OAD UNIVERSAL DRIVE SHAFT 420-530MM	-111502
	0.75, 1	4	QUICK RELEASE OAD UNIVERSAL DRIVE SHAFT 350-460MM	111501
	1, 1.25, 1.5	0	QUICK RELEASE OAD ZERO CAMBER DRIVE SHAFT 330-440MM	111506
	1.75	0	QUICK RELEASE OAD ZERO CAMBER DRIVE SHAFT 421-491MM	-111507
SEAT WIDTH 20"	0.75, 1, 1.25, 1.5	2	QUICK RELEASE OAD UNIVERSAL DRIVE SHAFT 350-460MM	111501
	1.75	2	QUICK RELEASE OAD UNIVERSAL DRIVE SHAFT 420-530MM	-111502
	0.75, 1	4	QUICK RELEASE OAD UNIVERSAL DRIVE SHAFT 350-460MM	111501
	1, 1.25, 1.5	0	QUICK RELEASE OAD ZERO CAMBER DRIVE SHAFT 330-440MM	111506
	1.75	0	QUICK RELEASE OAD ZERO CAMBER DRIVE SHAFT 421-491MM	-111507

NOTES:

#FOR THIS CONFIGURATION, ONE WHEEL MUST BE REMOVED BEFORE THE DRIVESHAFT CAN BE INSTALLED. THE SECOND WHEEL CAN BE INSTALLED ONCE THE DRIVE SHAFT IS IN POSITION.

-FOR THIS CONFIGURATION, TOWER ASSEMBLIES ARE TO BE MOUNTED OUTBOARD OF THE FRAME.

One Arm Drive (OAD)

DRIVE SHAFT CONFIGURATIONS FOR ROGUE WITH T-ARMS				PART NUMBER
ROGUE SEAT WIDTH	WHEEL SPACING	CAMBER	DESCRIPTION	PART NUMBER
SEAT WIDTH 11"	1.75	0	QUICK RELEASE OAD ZERO CAMBER DRIVE SHAFT 177-255MM	111503
	1.75	2	QUICK RELEASE OAD UNIVERSAL DRIVE SHAFT 195-235MM	111628
SEAT WIDTH 12"	1.75	0	QUICK RELEASE OAD ZERO CAMBER DRIVE SHAFT 177-255MM	111503
	1.75	2	QUICK RELEASE OAD UNIVERSAL DRIVE SHAFT 220-280MM	111498
SEAT WIDTH 13"	1.75	0	QUICK RELEASE OAD ZERO CAMBER DRIVE SHAFT 225-295MM	111504
	1.75	2	QUICK RELEASE OAD UNIVERSAL DRIVE SHAFT 220-280MM	111498
SEAT WIDTH 14"	1.75	0	QUICK RELEASE OAD ZERO CAMBER DRIVE SHAFT 225-295MM	111504
	1.75	2	QUICK RELEASE OAD UNIVERSAL DRIVE SHAFT 270-330MM	111499
SEAT WIDTH 15"	1.75	0	QUICK RELEASE OAD ZERO CAMBER DRIVE SHAFT 260-370MM	111505
	1.75	2	QUICK RELEASE OAD UNIVERSAL DRIVE SHAFT 295-370MM	111500
SEAT WIDTH 16"	1.75	0	QUICK RELEASE OAD ZERO CAMBER DRIVE SHAFT 260-370MM	111505
	1.75	2	QUICK RELEASE OAD UNIVERSAL DRIVE SHAFT 350-460MM	111500
SEAT WIDTH 17"	1.75	0	QUICK RELEASE OAD ZERO CAMBER DRIVE SHAFT 330-440MM	111506
	1.75	2	QUICK RELEASE OAD UNIVERSAL DRIVE SHAFT 350-460MM	111501
SEAT WIDTH 18"	1.75	0	QUICK RELEASE OAD ZERO CAMBER DRIVE SHAFT 330-440MM	111506
	1.75	2	QUICK RELEASE OAD UNIVERSAL DRIVE SHAFT 350-460MM	111501
SEAT WIDTH 19"	1.75	0	QUICK RELEASE OAD ZERO CAMBER DRIVE SHAFT 330-440MM	111506
	1.75	2	QUICK RELEASE OAD UNIVERSAL DRIVE SHAFT 350-460MM	111501
SEAT WIDTH 20"	1.75	0	QUICK RELEASE OAD ZERO CAMBER DRIVE SHAFT 421-491MM	111507
	1.75	2	QUICK RELEASE OAD UNIVERSAL DRIVE SHAFT 420-530MM	111502

NOTE: TOWER ASSEMBLIES ARE TO BE MOUNTED OUTBOARD OF THE FRAME WHEN T-ARMS ARE USED.



Ki Mobility
5201 Woodward Drive
Stevens Point, Wisconsin 54481
715-254-0991
www.kimobility.com

