

Otto Bock[®]

QUALITY FOR LIFE



Nurmi Neo Service Manual

Table of Contents

| | |
|--|----------|
| 1 Preface | 2 |
| 2 Safety | 2 |
| 3 Maintenance Schedule and Required Tools | 3 |
| 4 Settings / Retrofit / Exchange | 6 |
| 4.1 Anterior Frame | 6 |
| 4.2 Posterior Frame | 7 |
| 4.3 Folding Mechanism | 8 |
| 4.4 Grip Bar | 9 |
| 4.5 Front Wheel | 12 |
| 4.6 Rear Wheel | 14 |
| 4.7 Reverse-roll Lock | 15 |
| 4.8 Storage Basket | 16 |
| 4.9 Driving Brake and Wheel Lock | 18 |
| 4.10 Gluteal Support | 20 |
| 4.11 Combined Pelvic and Gluteal Support | 20 |
| 4.12 Anti-tipper | 21 |
| 4.13 Caster Swivel Lock | 22 |
| 4.14 Friction Brake | 24 |
| 4.15 Seat | 25 |

1 Preface

Regular maintenance is important – it increases safety and service life of the product.

All rehab products should be checked and serviced once a year.

It is however recommended that rehab products be checked, readjusted and possibly serviced every 6 months if they

are used frequently or if the user is growing or the user's clinical picture changes.

For all service and maintenance work, use only original spare parts.

The service and maintenance work described in this manual should be performed by skilled specialist staff only and not by the user of the product.

This service and maintenance manual refers to the respective spare parts catalogs and instructions for use of the described products; therefore, please use all documents together.

Please use the maintenance schedules (check list) for duplication. Keep the completed maintenance schedules and hand over a copy to the customer.

| | Instructions for Use | Spare Parts Catalog |
|-----------|----------------------|---------------------|
| Nurmi Neo | 647G224 | 646K73 |

2 Safety

For all maintenance and repair work, there are a few points you should always observe:



Use suitable tools. (refer to page 3 and the following pages)



Wear appropriate clothing as well as gloves and safety glasses, if necessary.



Secure the product to prevent it from tipping over or falling off the workbench, for example.



Study the service and maintenance instructions before beginning your work.



You should become familiar with the functions of the product first. If you do not know the product, please first study the instructions for use before inspecting the product.



If no instructions for use are available to you, please order them from the manufacturer (refer to the overview of all Otto Bock Branches „Otto Bock Worldwide“).



You can also download the document from our homepage under www.ottobock.de or www.ottobock.com.



Clean / Disinfect the product before starting inspection. Please also refer to the instructions for use regarding any care instructions or specific product inspection information.



Many of the screw fastenings use thread lock or nylock nuts. If you have to undo such screw connections, please replace the respective nut or screw with a new thread and/or nylock nut. If new thread lock or nylock nuts are not available, use a liquid thread lock substance with medium strength (e.g. Loctite 241 or Euro Lock A24.20).

3 Maintenance Schedule and Required Tools

The following list shows you the tools and auxiliaries mentioned in the text.



Flex ratchet and
Socket wrench bits sizes 8 -19



Torque wrench
Measurement range 10 -25 Nm



Wrenches
Sizes 8 -19



Allen wrenches
Size 2.5 – 6



Screwdrivers
Blade width 2.5 mm



Phillips head screwdriver size 2



Plastic hammer



Hammer approx. 300 g



Water pump pliers DIN 8976
Handle width up to 32 mm



Side cutting pliers



Hand drill



Twist drill
Ø 4 mm



Stanley knife with sickle hooked blade and standard blade



Liquid thread lock "medium strength"



Pop rivet gun for rivets up to Ø 5 mm

| Maintenance Schedule for Regular Service | | Nurmi Neo Gait Trainers | | Customer: | | | |
|--|---|---|--|------------------------------|--|--------------------------|--|
| Item | Range | Inspection (check list) | | | | | |
| | Serial Number: | 1.) Function / Setting (Refer to 647G224 Instructions for Use) | | 2.) Damages/ Deformations | | 3.) Screw Connections | |
| | Nurmi Neo | | | | | | |
| 4.1 | Anterior Frame | | | x | | x | |
| 4.2 | Posterior Frame | - Height adjustment of the grip bar - Anti-tipper holder | | x x | | x x | |
| 4.3 | Folding Mechanism | - Folding mechanism | | x | | x | |
| 4.4 | Grip Bar | - Depth adjustment - Hand grip - Grip width adjustment (optional) - Forearm pads (optional) - Padding for forearm pads (option) | | x x x x x | | x x x | |
| 4.5 | Front Wheel | - Tires - Running behaviour of the wheels - Swiveling of the wheel forks | | x x x | | x x | |
| 4.6 | Rear Wheel | - Tires - Running behavior of the wheels | | x x | | x x | |
| 4.7 | Reverse-roll Lock | - Reverse-roll lock | | x | | x | |
| | Accessories | | | | | | |
| 4.8 | Storage Basket | - Basket - Holder | | x x | | x x | |
| 4.9 | Driving Brake and Wheel Lock | - Wheel Locks | | x | | x | |
| 4.10 | Gluteal Support | - Support - Holder | | x x | | x x | |
| 4.11 | Gluteal and Pelvic Support | - Supports - Holder | | x x | | x x | |
| 4.12 | Anti-Tipper | - Anti-tipper | | x | | | |
| 4.13 | Caster Swivel Lock | - Opening and closing the caster swivel lock - Straight drive - Bumper ball | | x x x | | x x x | |
| 4.14 | Friction Brake | - Friction brake | | x | | x | |
| 4.15 | Seat | - Folding mechanism - Seat pad | | x x | | x x | |
| | Do the settings of the gait trainer comply with the user's requirements? | | | | | | |
| The maintenance was carried out by: | | | | on: | | | |

4 Settings / Retrofit / Exchange

4.1 Anterior Frame



Exchanging the Anterior Frame

Loosen and remove the marked screw connections, left and right, between the anterior frame and the folding mechanism (refer to 4.3) and the screw connections between the posterior and anterior frame.

Attention!

When you disassemble the frame parts, the gait trainer folds together. Lay all parts carefully on the work surface.



Then disassemble the front wheels and the wheel forks (refer to 4.5).

For re-assembly, please proceed in reverse order.

Use new, self-locking nuts.

4.2 Posterior Frame



Exchanging the Posterior Frame and the Anti-tipper Holder

It is possible to individually exchange the right and left posterior frame on models size 1 and 2. Model size 3 allows only the complete exchange of the posterior frame.

First remove the grip bar (refer to 4.4).

Loosen and remove the marked screw connections (left figure), on the corresponding side, between the posterior frame and the folding mechanism (refer to 4.3) and the screw connections between the posterior and anterior frame.

Then remove the rear wheel (refer to 4.6) and the reverse-roll lock (refer to 4.7).

After loosening and removing the rear wheel, you can pull the **anti-tipper holder** off the posterior frame and exchange it.

For re-assembly, please proceed in reverse order.

Use new, self-locking nuts.

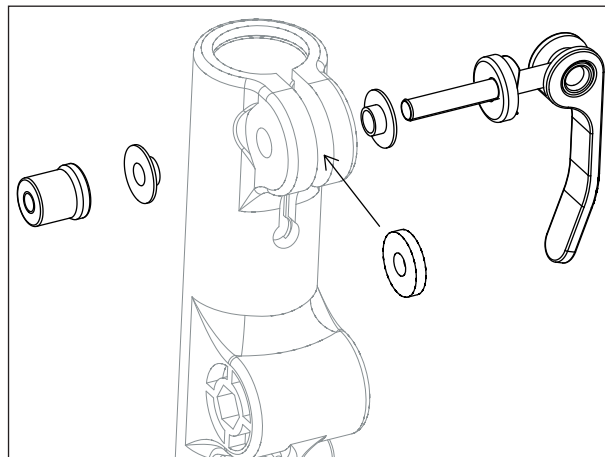

Exchanging the Multifunction Part

Loosen and remove the marked screw connections on the multifunction part.

Afterwards you can pull the posterior frame tube out of the multifunction part.

A mandrel that prevents the turning of the posterior frame is located in the multifunction part.

For re-assembly, please proceed in reverse order.

Exchanging the Quick-release Mechanism

First pay attention to the arrangement of the bushings and washers so that you can reassemble the quick-release mechanism later.

Loosen and remove the knurled nut and pull the quick-release mechanism and all the bushings and washers out of the multifunction part.

Follow the instructions for adjusting the quick-release mechanism in the instructions for use.

For re-assembly, please proceed in reverse order.

4.3 Folding Mechanism

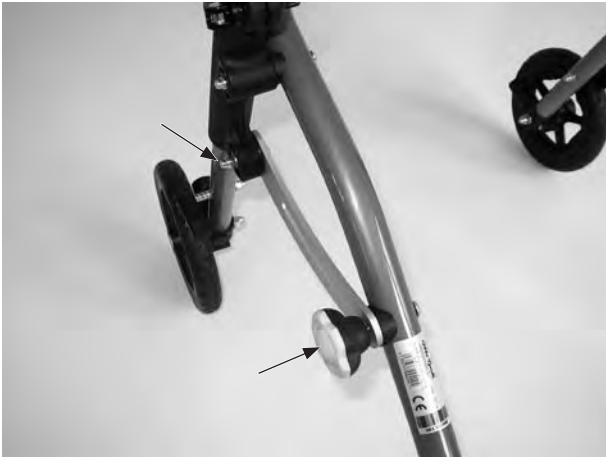

Exchanging the Folding Mechanism

First unscrew the clamping handle completely and remove it.

Loosen and remove the screw connection between the folding lever and the posterior frame and pull off the folding lever with all the washers and bushings.



Finally, loosen and remove the safety bushing and the oval head Allen screw.

Proceed in the same manner as described with the folding mechanism on the opposite side.

For re-assembly, please proceed in reverse order.

Use new, self-locking nuts.

4.4 Grip Bar



Exchanging the Grip Bar (all models)

Loosen the quick-release mechanism on both sides and pull the grip bar out until the height arrest engages.

Then press in the tripod spring button and completely remove the grip bar from the posterior frame. For re-assembly, please proceed in reverse order.

When setting the height and depth **of the grip bar**, please observe the specifications in the Instructions for Use



Exchanging the Hand Grips (all models)

Carefully cut open the hand grip with a blade and remove the hand grip from the grip bar tube.



Stick the new hand grip onto the grip tube and press the grip tube against the floor until the hand grip has completely slid on to it.



Exchanging the Grip Bar Tube Bend and the Grip Bar Attachment Device

With the standard grip bar design, **remove the hand grips.**

For the grip bar with **universal grips, the mini grip bar and the extra high grip bar with forearm pads, loosen the screw connection of the inclined cone and pull out the grips / forearm pads that were inserted into the grip bar tube bend.**



Loosen the screw connection on the left and right grip bar attachment device and pull the grip bar tube bend out of the grip bar attachment device.

You can now remove the grip bar attachment device from the posterior frame and replace it as described under **Exchanging the Grip Bar.**

For re-assembly, please proceed in reverse order.



Setting the Distances between Grips and the Grip Heights of Grip Bars with Universal Grips and Mini Grip Bars

Observe the specifications in the Instructions for Use.



Adjusting the Forearm Pads and the Grip Position of the Extra High Grip Bar with Forearm Pads

Observe the specifications in the Instructions for Use.



Exchanging the Padding for the Forearm Pad

Pull off the padding from the edge of the forearm pad.

For re-assembly, please proceed in reverse order.

4.5 Front Wheel



Exchanging a Front Wheel

Loosen and remove the screw connection of the front wheel and take the front wheel out of the wheel fork.

For re-assembly, please proceed in reverse order.

Use new, self-locking nuts.

Tighten the screws with a **torque** of **10 Nm**.



Attention!

Wheels with EVA foam tires must be replaced, if the material shows signs of cracking or damage and when the tread becomes worn down to such an extent that there is only 5 mm of radius left on the outer edges of the tire.



Exchanging a Caster Fork

Loosen and pull out the screw in the caster fork and remove the caster fork together with the screw, the distance piece and all washers from the anterior frame.

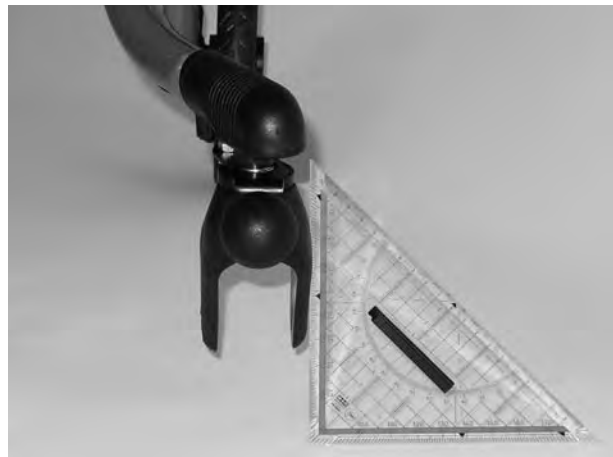

When re-assembling, first tighten the screw only slightly.

Place the front wheel fork in the driving direction at an angle.

Tighten the screw with a **torque** of **20 Nm**.

Use a new, self-locking screw.



Exchanging a Swivel Lock Housing

After disassembling the caster fork, you can remove the swivel lock housing from the frame tube and replace it.



Exchanging a Thrust Piece and the Piston

First, disassemble the caster fork and the swivel lock housing.

Unscrew the thrust piece from the piston.
Remove the piston from the frame tube.

For re-assembly, please proceed in reverse order.

4.6 Rear Wheel



Exchanging a Rear Wheel

Loosen and remove the screw connection of the rear wheel and remove the rear wheel from the posterior frame. Pay attention to the spacer washer between the wheel and the frame and the collar bush in the anti-tipper holder.

For re-assembly, please proceed in reverse order. Use a new, self-locking nut. Tighten the screw connection with a **torque of 20 Nm**.

Attention:

Wheels with EVA foam tires must be replaced, if the material shows signs of cracking or damage and when the tread becomes worn down to such an extent that there is only 5 mm of radius left on the outer edges of the tire. (refer to 4.5)



Exchanging an Anti-tipper Holder

Loosen and remove the screw connection of the rear wheel and remove the rear wheel from the posterior frame.

Remove the anti-tipper holder from the posterior frame.

For re-assembly, please proceed in reverse order.

4.7 Reverse-roll Lock



Exchanging a Reverse-roll Lock

Press the lock (plastic piece) as far as possible against the compression spring, until you can take hold of the axle with water pipe pliers. Loosen and remove the nuts from the axle and remove the axle with the lock from the posterior frame. Pull down from the axle the compression spring and the lock to be exchanged. For re-assembly, please proceed in reverse order. Use a new, self-locking nut.



Setting a Reverse-roll Lock

Set the axle of the reverse-roll lock so that the mandrel on the axle end (as shown here) is turned approx. 30° in the driving direction.

4.8 Storage Basket



Retrofit of the Storage Basket

First decide whether the storage basket should be attached in the middle or laterally shifted to the right or left.

Fasten the locking disk at the selected position.



Mounting the Quick-release Lock

Attach both plastic bars to the grip bar.

Push the housing of the quick-release lock onto the plastic bar and screw on the plastic bar so that the quick-release lock faces upwards at an angle.

Insert the cable clamp into the housing of the quick-release lock.



Wrap the cable around the locking disk and, from above, through the opening on the backside of the housing and through the cable clamp.

Let the ends of the cable overlap below.



First, clamp the cable with a cable clamp in place on one side. Pull the cable on its free end taut and fasten the cable with a second cable clamp.

Bend the overlapping cable ends over and toward the middle.

Turn the quick-release lock on the grip rail downwards until the cable is tense. Now firmly re-tighten the four screws in the housing.

For disassembling, please proceed in reverse order.



Mount the adapter plate on the basket in the uppermost position.



Use

The quick-release lock engages automatically when hanging on the basket. The basket can be detached once again by pressing the red button.

4.9 Driving Brake and Wheel Lock



Retrofit of the Driving Brake and Wheel Lock / Assembly of the Brake Handle

First, assemble the brake handle **behind** the hand grips on the grip bar.

For disassembling, please proceed in reverse order.



When assembling on an extra high grip bar with forearm pads, the brake handles are screwed onto the perpendicular handle tubes with additional plastic bushings.



Pull the brake handle up to the stop. Open the set screw in the brass insert and pull the **inner cable** through the brake until the nipple hits the brass insert. Then tighten the set screw.



Now thread the cable housing **onto the cable** and fasten the brake cable with a cable tie on the frame below the eccentric lever.

For disassembling, please proceed in reverse order.

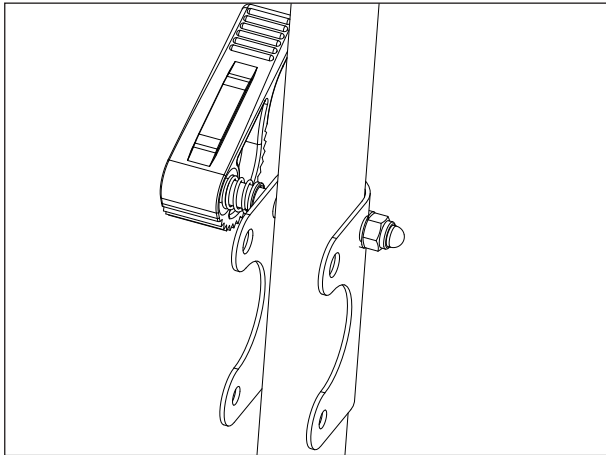

**Retrofit of the Driving Brake and Wheel Lock /
Assembling the Brakes (left and right)**

First disassemble the reverse-roll lock as described under 4.7.

Attach the brake bracket to the posterior frame and fasten the bracket by re-attaching the reverse-roll lock.

The open side of the bracket must face the non-driving direction.

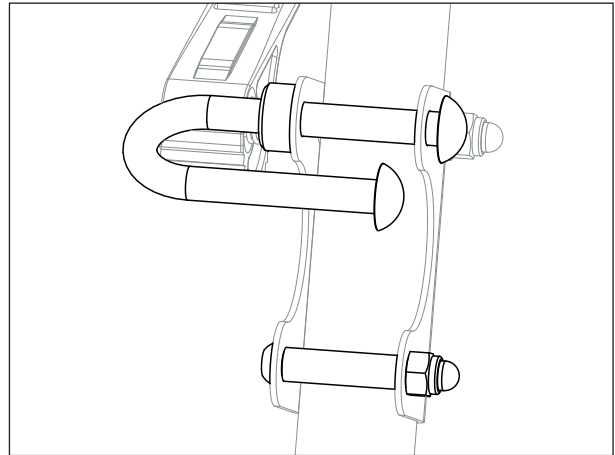

Insert a screw with bushing through the lower bore holes of the bracket and close this screw connection. Place the set collar on the longer side of the brake bar and pull the brake bar through the upper bore holes of the bracket.

Press an axle clamp cap on each end of the brake bar.

Screw the set collar onto the brake bar so that the brake bar can move up and down easily but not laterally, or at least as little as possible laterally.

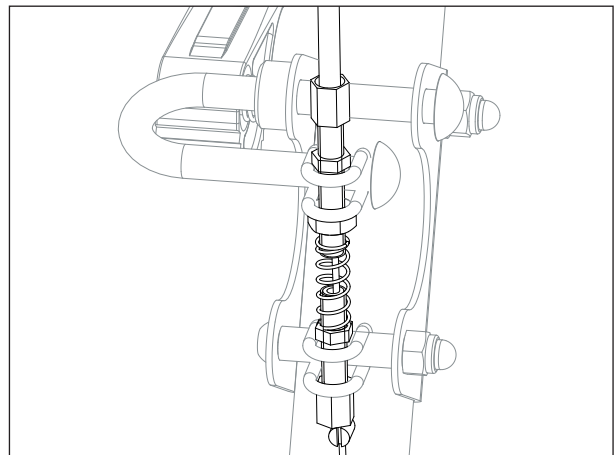
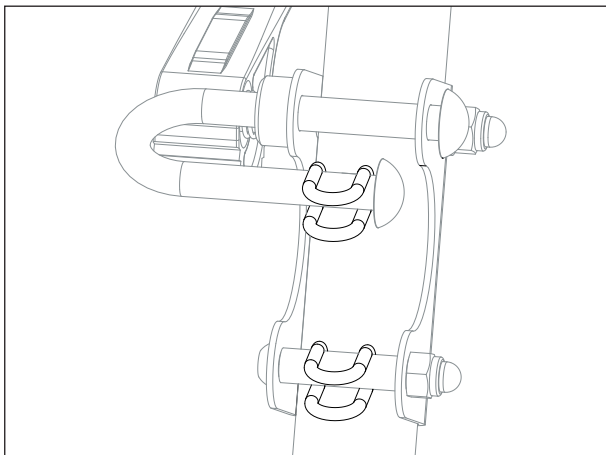

Stick a counter bearing onto each brake bar and each bushing. (Left figure) Turn a counter nut up to the head of the longer of the two set screws and stick the set screws through the upper counter bearing. Secure these set screws with another counter nut. Stick the shorter set screw from below through the lower counter bearing and secure it with a counter nut. Now stick the cable housing from above through the longer set screw, the compression spring and the shorter set screw. Tense the cable until the brake bar stands approx. 2 mm (nickle coin) above the wheel. Pull the screw die on the cable up to the set screw and tighten the screw die. Finally attach the cable end sleeve onto the cable and carefully squeeze the cable end sleeve with cutting pliers to fix it. **Setting the Brakes:** The brake force must be checked and readjusted from time to time. Unscrewing the upper set screws increases the tension and the brake force. The set screw is secured in place by two counter nuts. With the brake levers engaged with the last tooth, the wheels must be secured so that the gait trainer cannot roll away (parking brake). When the brake levers are released, the wheels should run freely.

4.10 Gluteal Support



Attachment of the Gluteal Support Bracket

Place the two saddle washers around the grip bar tube. First, stick only one screw through and screw on the mounting plate lightly. Then stick the second screw through the saddle washers and screw it in tightly.

The angle of the bracket can be adjusted to meet individual needs. Finally, tighten both screws.



Exchanging the Padding for the Gluteal Support

Loosen and remove both countersunk head screws and detach the padding from the holder.

For re-assembly, please proceed in reverse order.

4.11 Combined Pelvic and Gluteal Support



Please observe the information given in the Instructions for Use Manual.



Exchanging the Padding

Loosen and remove both carriage bolts and detach the padding from the clip.

For re-assembly, please proceed in reverse order.

After slightly loosening the carriage bolts, the padding on the support bracket can be shifted and its angle adjusted.

4.12 Anti-tipper



Retrofitting and Setting the Anti-tipper

Please observe the information given in the Instructions for Use Manual.

4.13 Caster Swivel Lock



Retrofitting the Swivel Lock

Disassemble the front wheels and wheel forks as described under 4.5.

Locate the catch plate onto each caster fork as shown in the figure above.



Carefully bore through the forks with a \varnothing 4 mm drill bit.



Fasten the catch plate to the caster fork with a rivet as shown here.



Adjusting the Swivel Lock Housing

The swivel lock housings can be shifted on the anterior frame tube (outer/inner position) and are guided by means of a spring thrust piece.



Before mounting the caster forks adjust the tension on the thrust piece using a flat bladed screwdriver so the housing can be operated without too much effort.

Mount the wheel forks and front wheels as described under 4.5.

When you want to drive straight forward, the catch plate must be below the swivel lock housings.



Adjusting Straight-line Movement

First mount the hexagon head screws and the cap nuts in the catch plate.

Tighten the screw connection until you can still move the screws in the slotted holes.



Close the swivel lock by pulling the housing to the outside and tightening the cap nuts.

Turn the fork so that the gait trainer will move straight forward.

Now tighten the screw using a wrench, open the swivel lock and turn the caster fork to the side.

Finally, tighten the screw connection using two wrenches.

4.14 Friction Brake



Retrofitting the Friction Brakes

Disassemble the rear wheels and the anti-tipper holder as described under 4.6.

Place the bolt adapter and the set screw in the anti-tipper holder.



Locate the anti-tipper holder once again on the posterior frame.

Replace the spacing washer ...



...with the friction plate.

Assemble the rear wheels as described under 4.6.



Setting the Friction Brakes

Please observe the information given in the Instructions for Use.

4.15 Seat



Retrofitting the Seat

First, remove the protective plugs from the anterior frame tube.

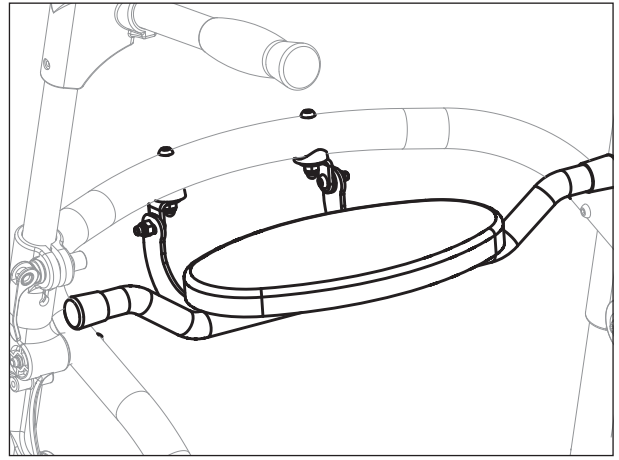

Screw on the seat with the seat angle on the anterior frame.

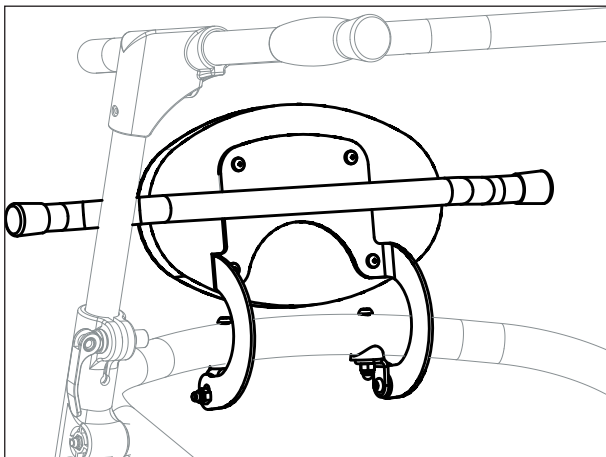

Exchanging the Foam Seat Padding

Loosen and remove the four screws on the lower side of the seat padding and remove the padding from the holder.

For re-assembly, please proceed in reverse order.

Hersteller/Manufacturer:

Otto Bock HealthCare GmbH

Max-Näder-Straße 15 · 37115 Duderstadt/Germany

National: Telefon 0 55 27-848 1461/1462/1463 · Fax 0 55 27-848 14 60

International: Phone +49-5527-848-1304/1562/1590/1594/3663 · Fax +49-5527-848-1676

e-mail: reha@ottobock.de · Internet: <http://www.ottobock.com>

Versandanschrift für Rücksendungen/Address for Returns

Otto Bock HealthCare GmbH

Lindenstraße 13 · 07426 Königsee/Germany



Otto Bock HealthCare GmbH has been certified by the German Society for the Certification of Quality Assurance Systems (DQS) in accordance with DIN EN ISO 9001 standard, reg. no. 779 (management system)